

# Techn. Daten Richard

Bohlenaußenmaß (B x T): 575x 535 cm

Wandaußenmaß: 555 x 515 cm · Bohlenstärke:70mm

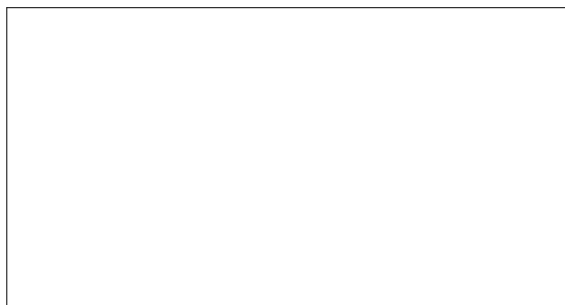
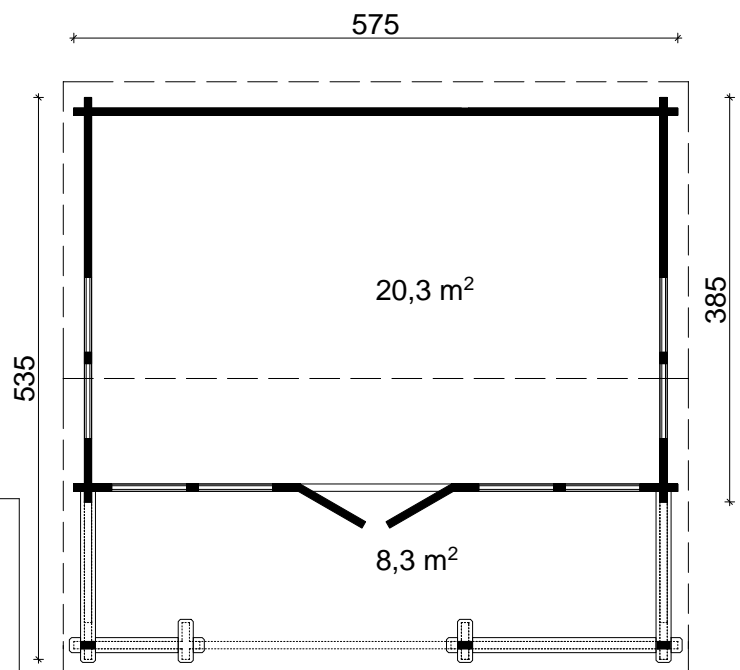
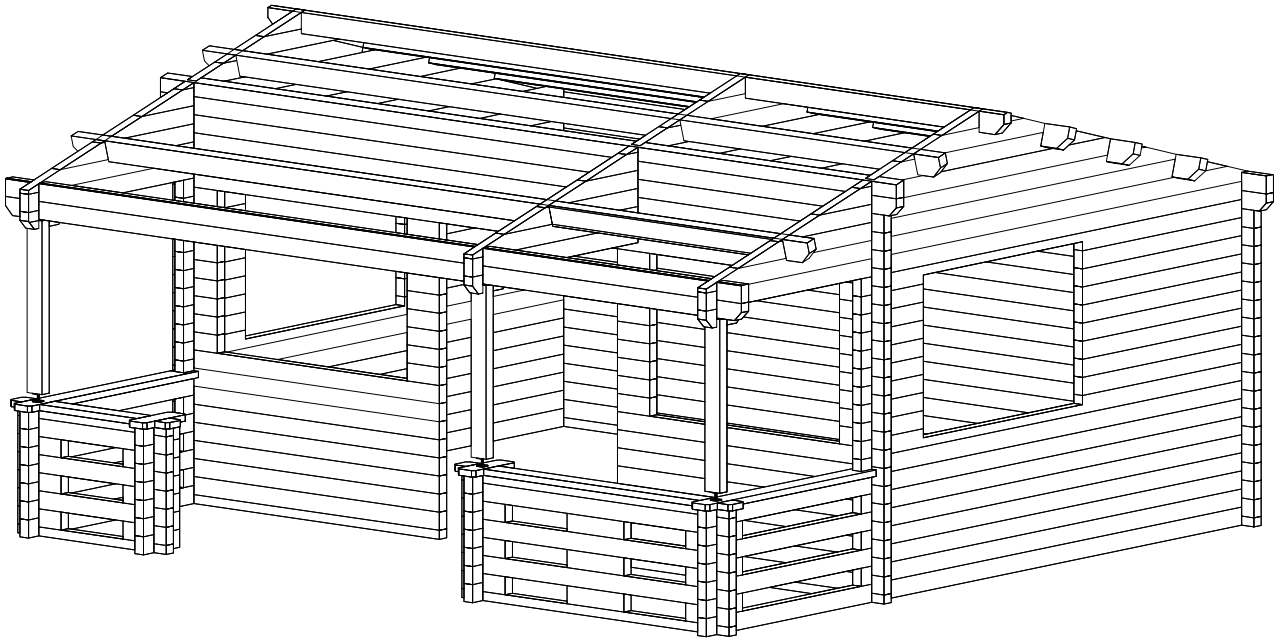

Achtung : Alle angegebenen Maße sind ca. - Maße !

# Richard 70/ 575 x 535 cm - Ground plan / Wandplan

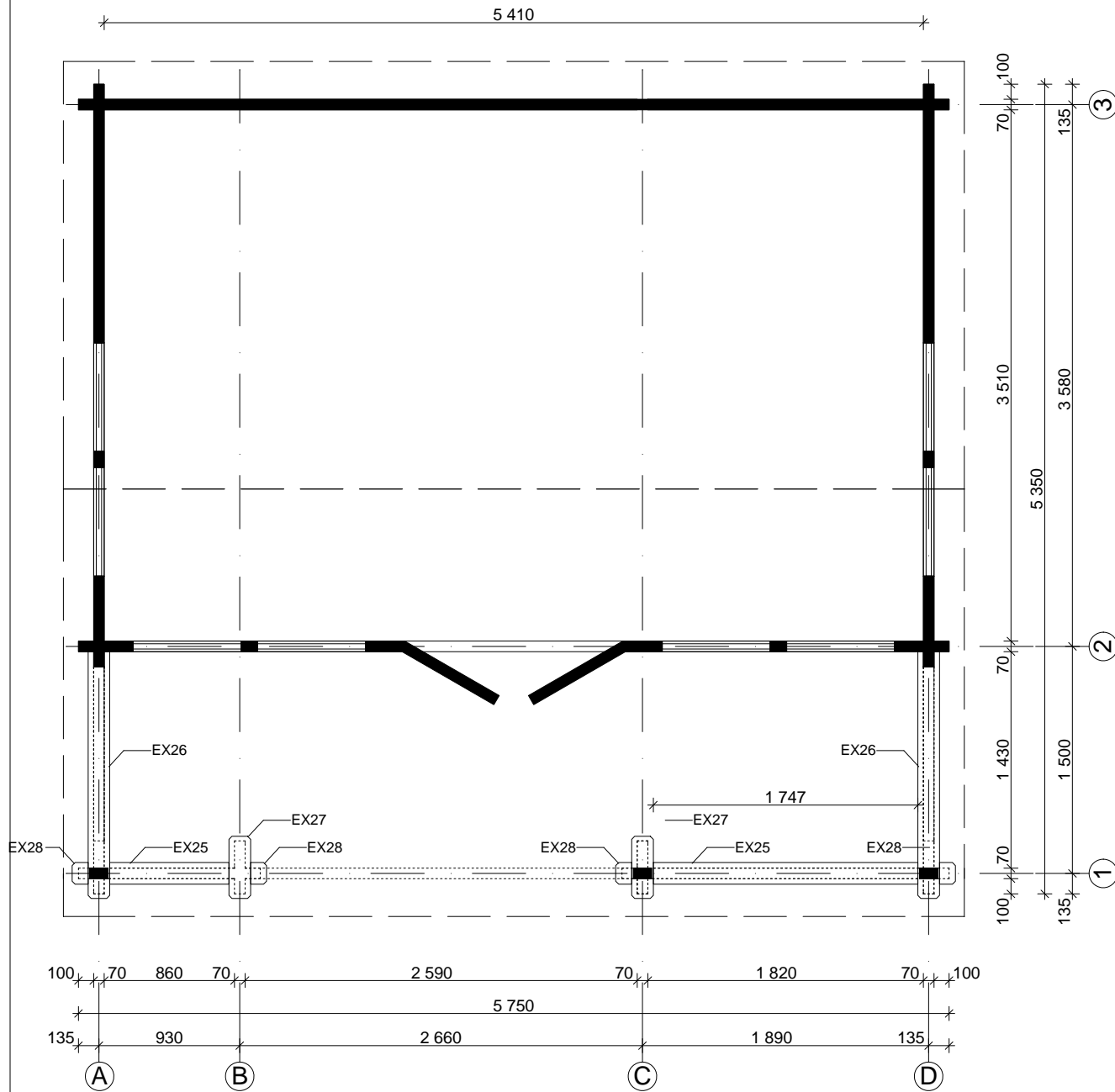

# Richard 70/ 575 x 535 cm - Foundation / Fundament

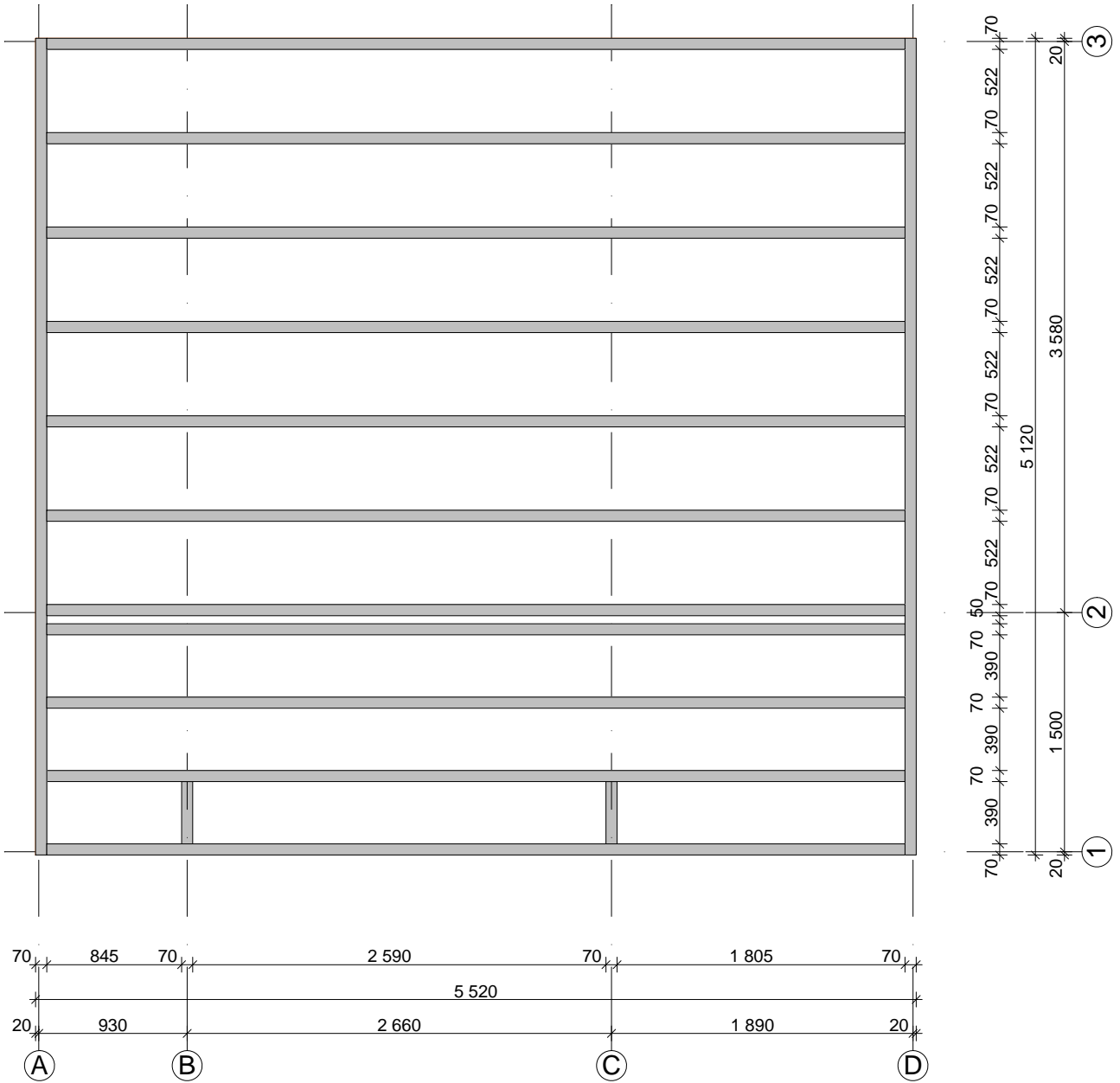

# Richard 70/ 575 x 535 cm - 1

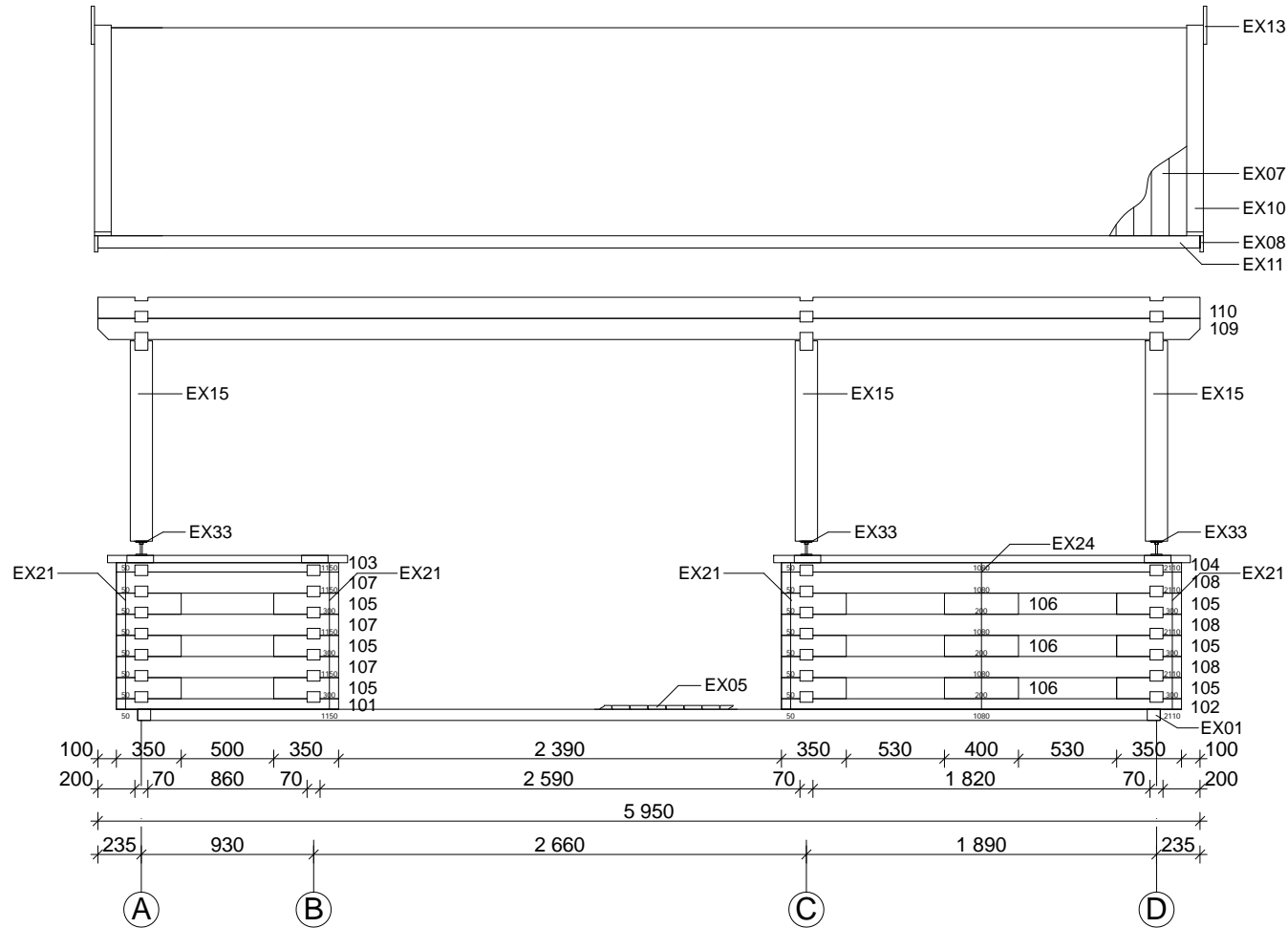

# Richard 70/ 575 x 535 cm - 2

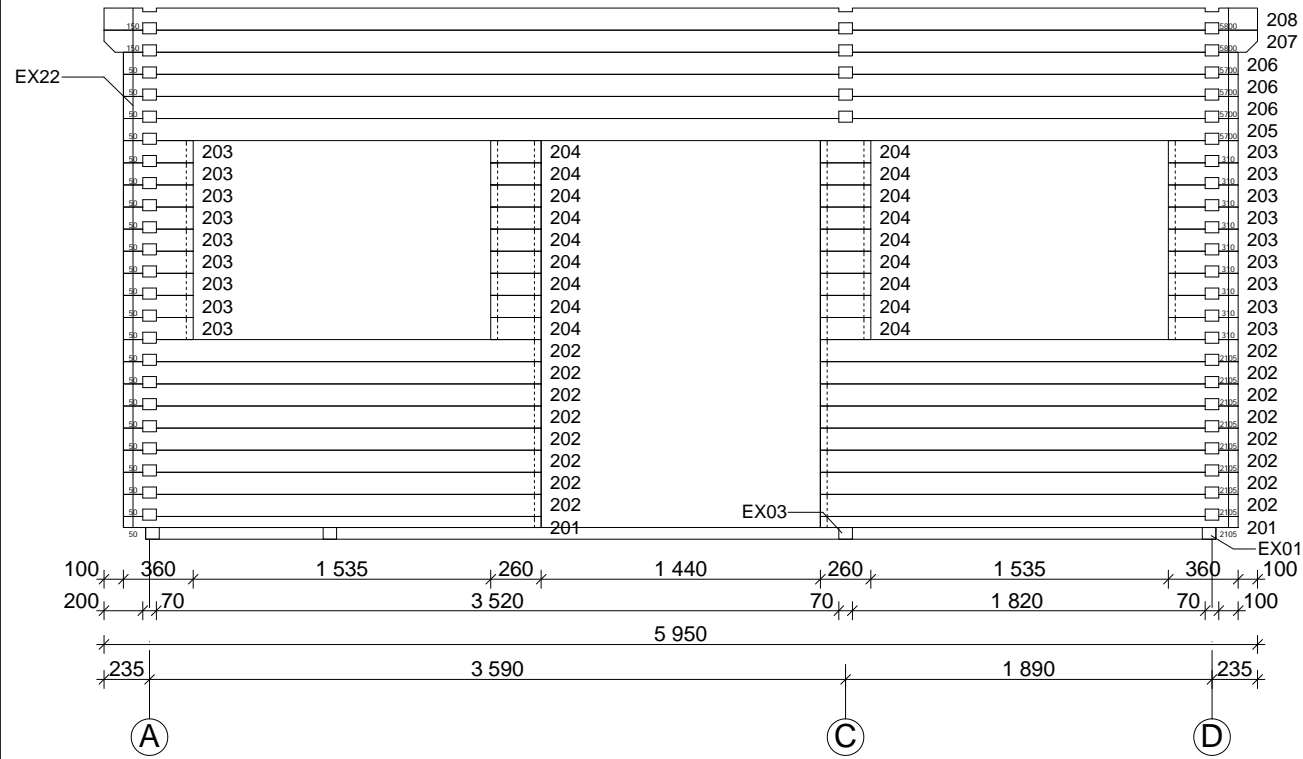

# Richard 70/ 575 x 535 cm - 3

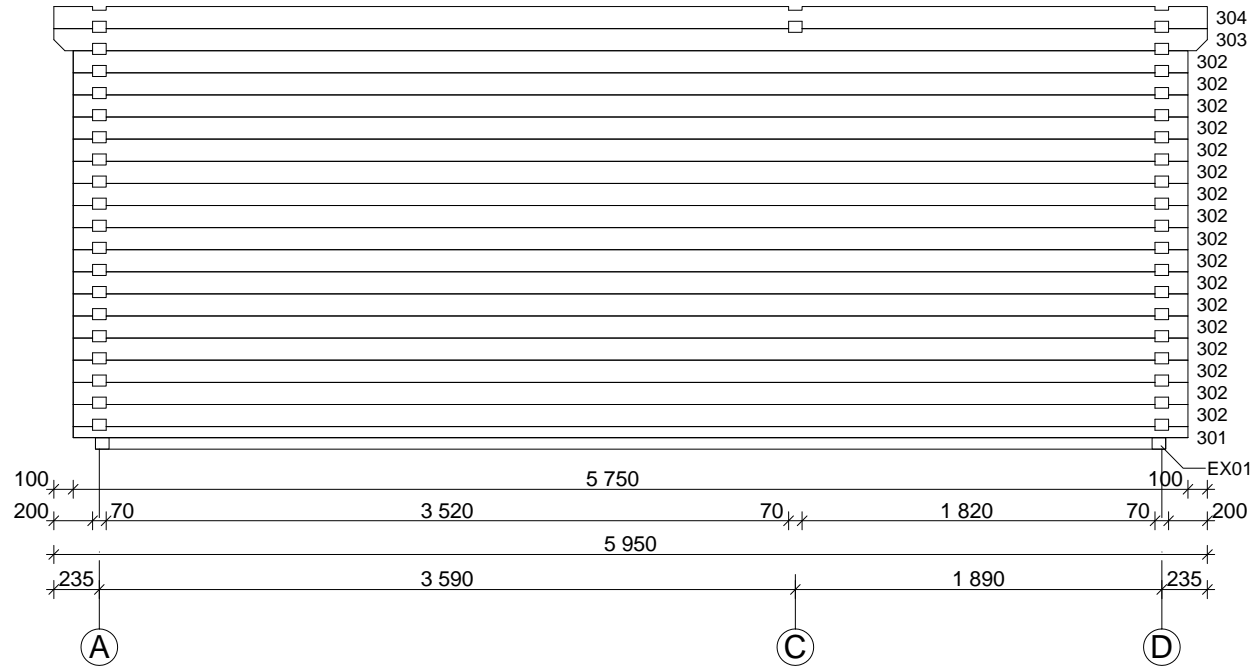

# Richard 70/ 575 x 535 cm - A ; B

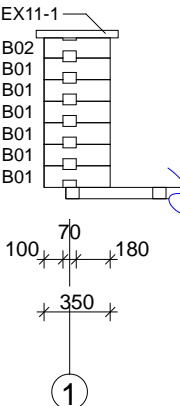
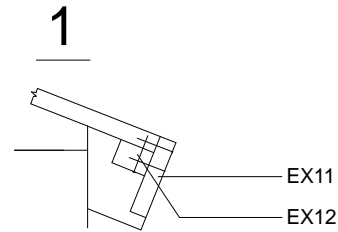
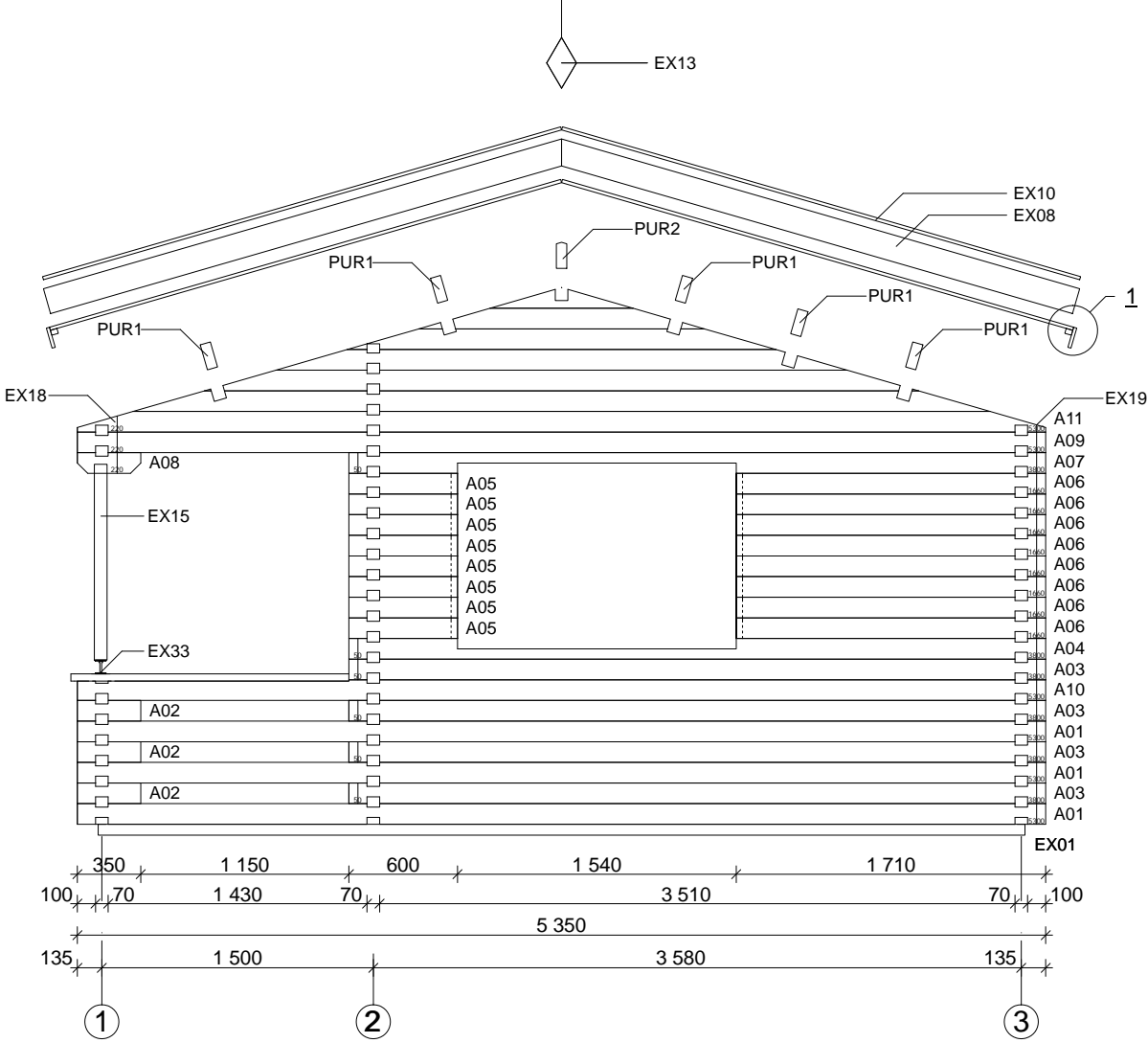

350			1 150			600		1 540			1 710		EX01
100	70	1 430	70	3 510	70	100							
5 350					3 580								
135	1 500		135										
①			②			③							

# Richard 70/ 575 x 535 cm - C

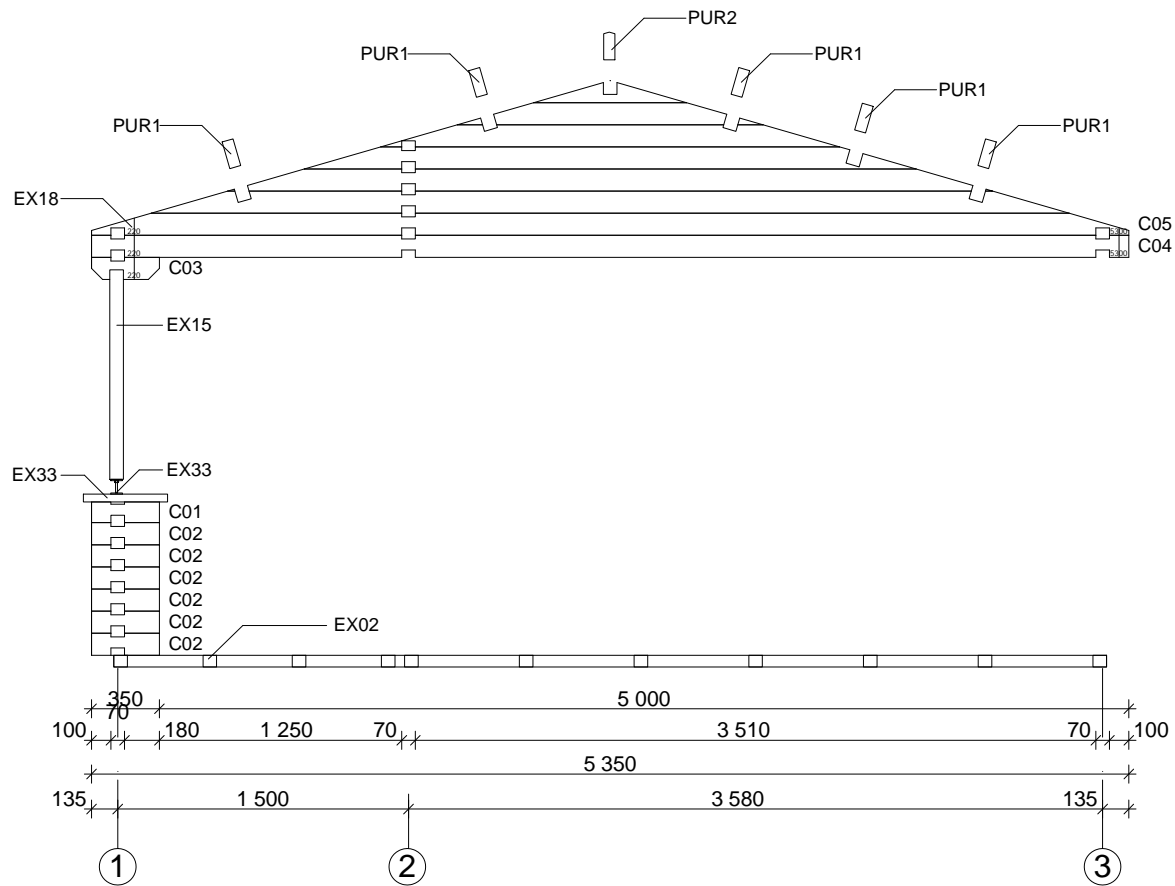





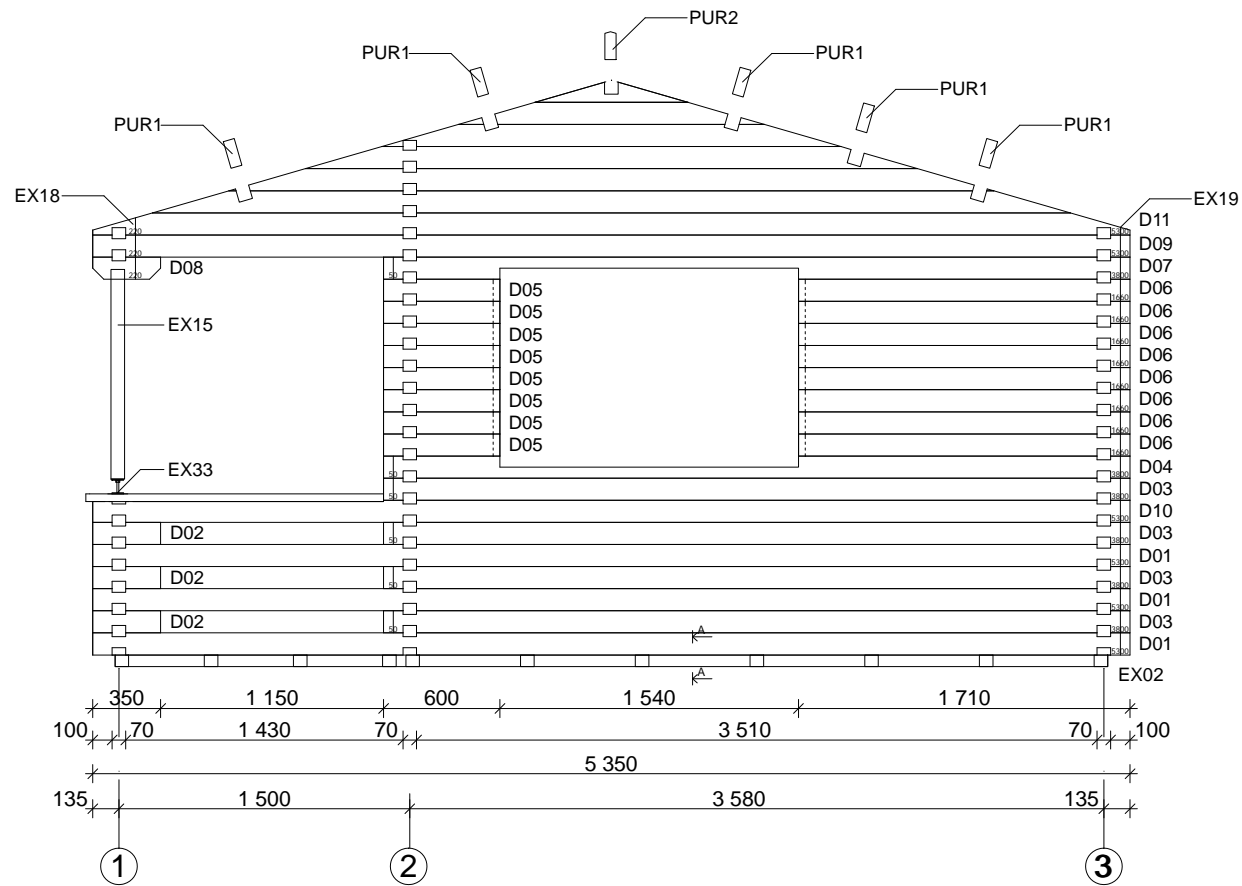







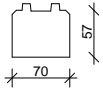

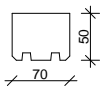
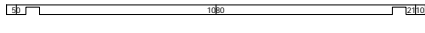

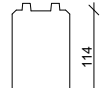

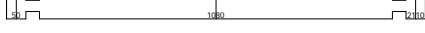



# Richard 70/ 575 x 535 cm - D







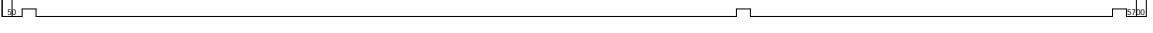

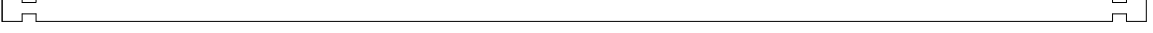
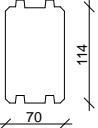
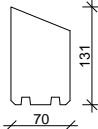







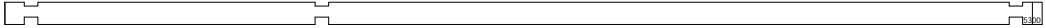
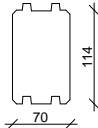

## Richard 70/ 575 x 535 cm - 1

Nr.		 mm	 mm	 x
101			1200	1
102			2160	1
103			1200	1
104			2160	1
105			350	12
106			400	3
107			1200	3
108			2160	3
109			5950	1
110			5950	1

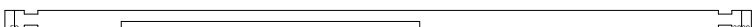



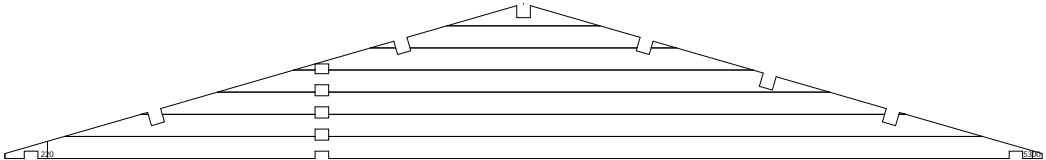

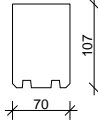

## Richard 70/ 575 x 535 cm - 2 ; 3

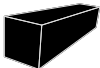
Nr.		 mm	 mm	 x
201			2155	2
202			2155	16
203			360	18
204			260	18
205			5750	1
206			5750	3
207			5950	1
208			5950	1
301			5750	1
302			5750	17
303			5950	1
304			5950	1

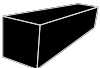
## Richard 70/ 575 x 535 cm - A ; B

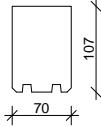
Nr.		 mm	 mm	 x
A01			5350	3
A02			350	3
A03			3850	4
A04			3850	1
A05			600	8
A06			1710	8
A07			3850	1
A08			350	1
A09			5350	1
A10			5350	1
A11			5350	1
B01		350	6	
B02			350	1

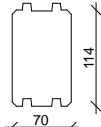
# Richard 70/ 575 x 535 cm - C

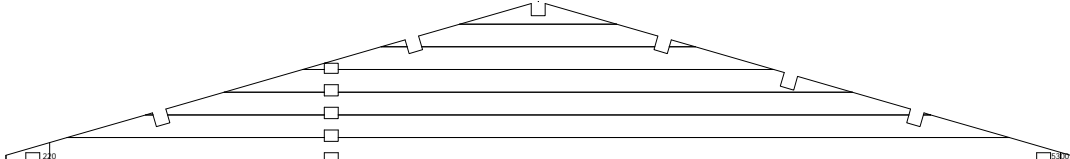
Nr.		 mm	 mm	 x
C01			350	1
C02			350	6
C03			350	1
C04			5350	1
C05			5350	1

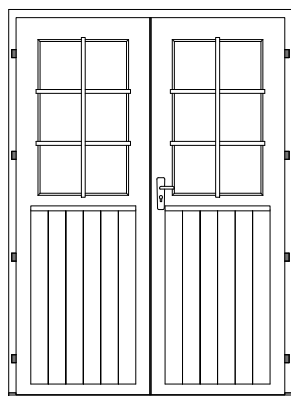

**Double door 1st.**

70 mm  
1425 x 1955 mm R

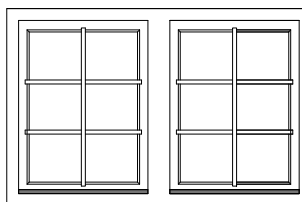







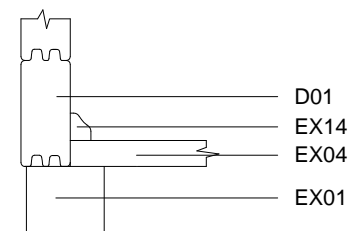







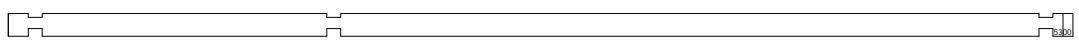
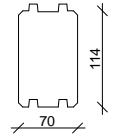

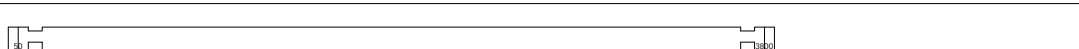
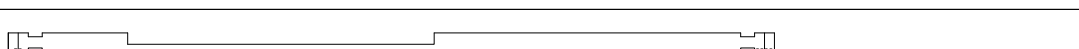
**Double window 4 st.**

70 mm  
1530 x 990 mm

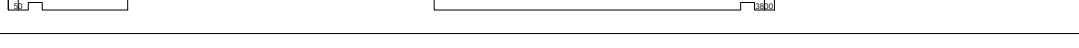

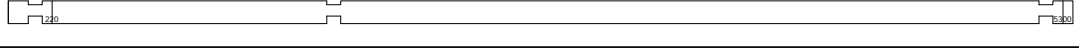
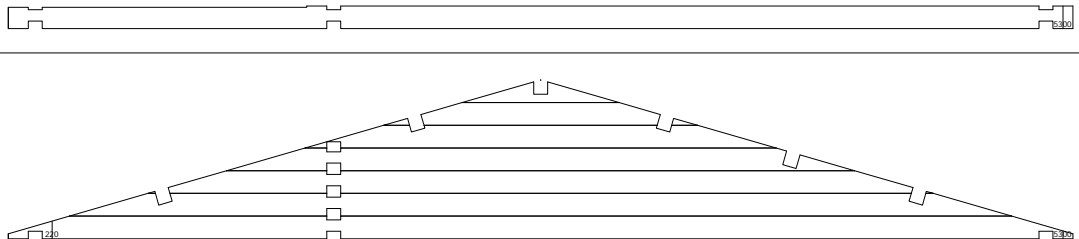
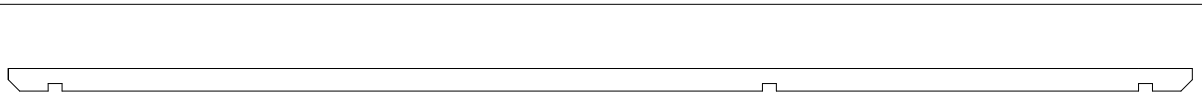

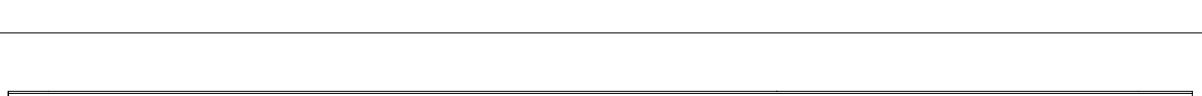







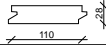
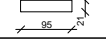
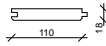

**A-A**

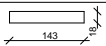
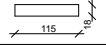
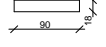
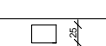
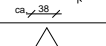

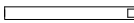
## Richard 70/ 575 x 535 cm - D

Nr.		 mm	 mm	 x
D01			5350	3
D02			350	3
D03			3850	4
D04			3850	1
D05			600	8
D06			1710	8
D07			3850	1
D08			350	1
D09			5350	1
D10			5350	1
D11			5350	1
PUR1		 70X143	5950	5
PUR2		 70X143	5950	1

## Richard70 mm / 575 x 535 cm - Teilliste

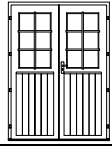
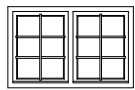
Nr.		 mm	 mm	 x
EX01			5120	2
EX02	Fundament	70 x 60	5380	11
EX03			390	2
EX04	Fußbodenbretter			3505
EX05	Terrassendielen		1500	56
EX06	Roofing felt		--	--
EX07	Roof board		2940	110+2
EX08	Giebelblende 		2980	4
EX09			-	-
EX10	Giebelabschlussbrett		2980	4
EX11	Traufenbrett		5950	2
EX12	Traufenleiste		5950	2
EX13	Raute			2
EX14	Fußleisten		ca. 18,0 m	
EX15	Post 	70 x 120	1080	3
EX16			-	-
EX17	Stütze 			3
EX18	Gewindestangen	∅ 10	360	3
EX19			2250	2
EX20			200	1
EX21			840	4
EX22			2720	2
EX23	Mutter, Scheibe			22
EX24	Dübel	∅ 16	150	4
EX25		40 x 143	800/1747	1/1
EX26	Terrassenabschlußbrett 		1630	2
EX27			106	4
EX28			410	2
EX29	Schrauben 4,0 x 40; 4,5 x 70; 5,0 x 100			1 Beutel
EX30	Nägel 2,2 x 50; 2,5 x 70			1 Beutel
EX38	Doppeltür 1425 x 1955 mm ISO /70 mm - R			1
EX39	Doppelfenster 1530 x 990 mm ISO / 70 mm			4
EX40	Schlaghölzer	70x114	300-400	