

Installation manual

Montageanleitung • Notice de montage • Istruzioni per il montaggio • Manual de montaje • Monteringsanvisning • Installatiegids • Montážní návod • Asennusohje • Installationsmanual • Instrukcja instalacji • Paigaldusjuhend

Log cabin PM56-4529

Blockhaus • Maisonnette en poutres • Casa di travi • Casa de jardin • Anneks • Tuinhuis • Zahradní domek • Timmerstuga • Hirsimökki • Dom z bali • Freesprussmaja

Width 445 x Depth 290 cm

Breite/Tiefe • Largeur/Profondeur • Lunghezza/Profondità • Ancho/Profundidad • Bredde/Dybde • Breedte/Diepte • Šířka/Hloubka • Leveys/Pituus • Bredd/Längd • Szerokość/Głębokość • Laius/pikkus

Log thickness 56 mm

Bohlenstärke • Épaisseur des murs • Spessore delle pareti • Grosor de pared • Tykkelse • Wanddicke • Tloušťka stěny • Seinän paksuus • Väggtjocklek • Grubość ścian • Seinapaksus



The producer shall have the right to make technical changes to the product • Technische Änderungen vorbehalten • Le producteur réserve le droit d'effectuer des modifications techniques au produit • Il produttore mantiene il diritto di apportare modifiche tecniche al prodotto • Reservado el derecho a modificaciones técnicas • Produsent forbeholder seg retten til å endre tekniske egenskaper ved produktet • Alle rechten en technische wijzigingen voorbehouden • Výrobce si vyhrazuje právo na technické změny výrobku • Valmistaja pidättää oikeuden tehdä tuotteeseen teknisiä muutoksia • Tillverkaren har rätt att utföra tekniska förändringar för produkten • Producent zastrzega sobie prawo do dokonywania zmian technicznych produktu • Tootja jätab endale õiguse muuta toote tehnilisi omadusi

OPERATING GRACE DOOR

1. Close the door

from inside or outside.



2. Lift up the handle.

Lifting up the handle activates hook/wedge bolts, which helps to stabilise the door position, allocate the door weight evenly across the hinges and the door frame.

This ensures long and functional lifetime to your door.



NB! In this position (handle lifted up) **the door is not locked!** As soon you push down the handle, door opens.

3. Lock the door.

NB! Without lifting the handle you are unable to lock the door (both from outside and inside).





Покраска и обслуживание садового дома

Древесина является природным материалом, который увеличивается или уменьшается в объеме в зависимости от погодных условий. Большие и маленькие трещины, разница в цветовых тонах и изменение тонов, а также изменения в структуре древесины не считаются дефектами, а являются результатом роста дерева и своеобразием древесины как природного материала.

Необработанная древесина (за искл. фундаментных брусьев) через некоторое время становится сероватой, может посинеть и заплесневеть. Чтобы защитить деревянные детали своего садового дома, Вы должны незамедлительно обработать их защитным средством для древесины.

Рекомендуем предварительно покрыть напольные доски бесцветным средством для пропитки дерева, особенно нижнюю сторону досок, к которой после монтажа дома доступа больше не будет. Только в таком случае можно остановить проникновение влаги.

Рекомендуем обязательно обработать средством для пропитки древесины также двери и окна. Важно обязательно обработать окна и двери как изнутри, так и снаружи! В противном случае они могут искривиться.

После монтажа дома рекомендуем при окончательной отделке использовать для защиты от погодных условий краску, которая защищает древесину от влаги и ультрафиолетового излучения.

При покраске используйте высококачественные рабочие инструменты и краски, следуйте инструкции по использованию краски, а также инструкциям производителя по безопасности и эксплуатации. Никогда не красьте под жарким солнцем или в дождливую погоду. Получите у специалиста консультацию в части красок, предназначенных для хвойной древесины, а также соблюдайте инструкции производителя краски.

Правильная покраска дома значительно продлит срок службы Вашего садового дома. Через каждые полгода рекомендуем Вам внимательно осматривать дом.

2 Подготовка к монтажу

Подготовка рабочих инструментов и деталей

Для монтажа садового дома Вам понадобятся следующие рабочие инструменты:



помощник по монтажу



лестница-стремянка



молоток

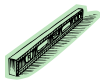

уровень



отвертка



пила



нож



рулетка



щипцы























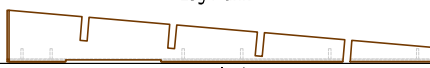

сверло

РЕКОМЕНДАЦИЯ: Чтобы избежать возможных заноз, рекомендуем во время монтажа надевать соответствующие защитные перчатки.



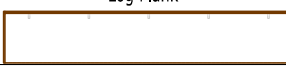



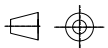









Желаем Вам успеха в установке садового дома и много радости на долгие годы!

Pos	SPECIFICATION-STÜCKLISTE-NOMENCLATURE-ELEMENTI Grace_12.4m2+4.1m2	Pcs	Profile (mm)	Length (mm)
1	Log Plank 	1	56 x 518	475
2	Log Plank 	1	56 x 518	3125
3	Log Plank 	3	56 x 535	475
4	Log Plank 	3	56 x 535	450
5	Log Plank 	3	56 x 535	475
6	Log Plank 	1	56 x 356	5980
8	Log Plank 	3	56 x 535	870
9	Log Plank 	1	56 x 535	1268
10	Log Plank 	1	56 x 352	2914
11	Log Plank 	1	56 x 518	4450
12	Log Plank 	2	56 x 535	4450
13	Log Plank 	1	56 x 535	5785
14	Log Plank 	1	56 x 98	5980
15	Log Plank 	1	56 x 518	2914
16	Log Plank 	2	56 x 535	1864
17	Log Plank 	3	56 x 535	400
18	Log Plank 	1	56 x 535	1864
19	Log Plank 	1	56 x 352	2914
23	Log Plank 	1	56 x 518	870
25	Log Plank 	2	56 x 535	1268
26	Log Plank 	3	56 x 535	900
28	Log Plank 	1	56 x 518	1268
29	Log Plank 	1	56 x 518	2914
30	Log Plank 	2	56 x 535	2914



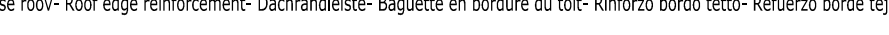
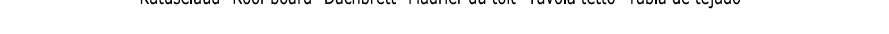

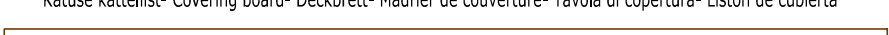
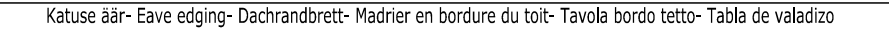
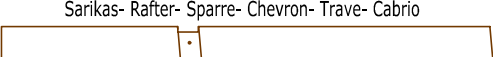
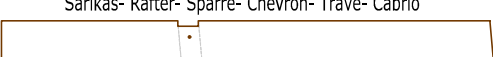
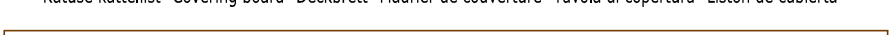
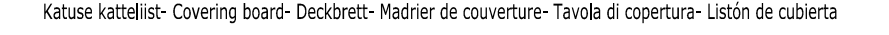
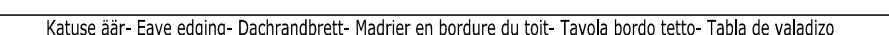

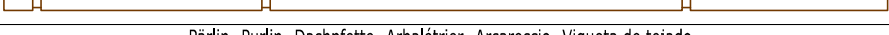

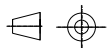

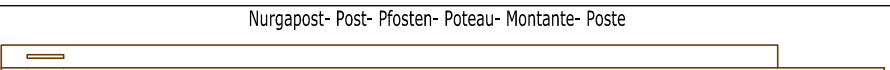
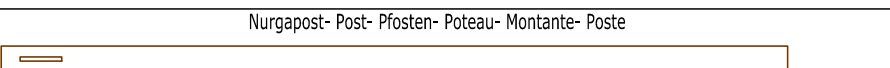
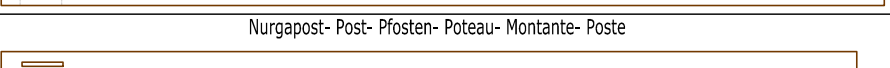
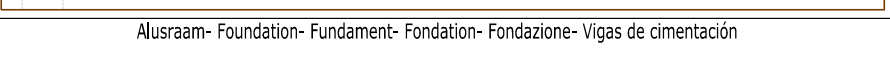

Object name

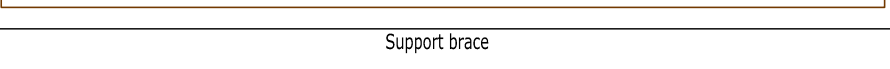
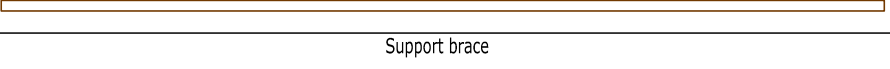
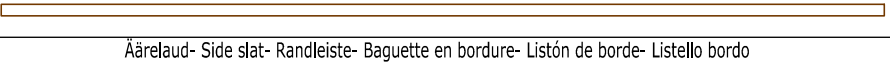
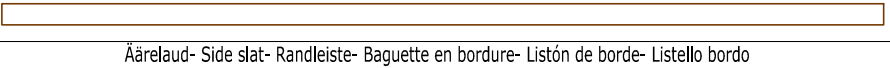
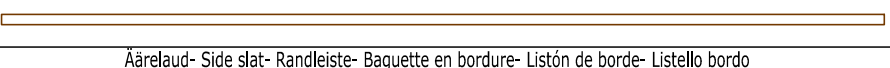
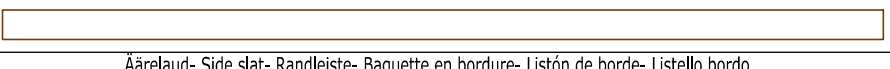
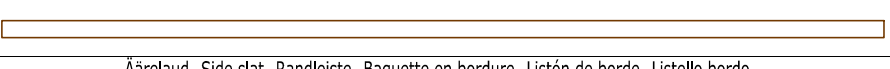
Grace_12.4m2+4.1m2

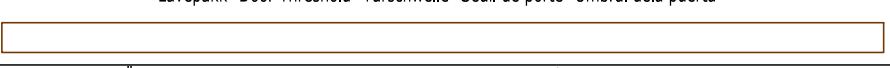
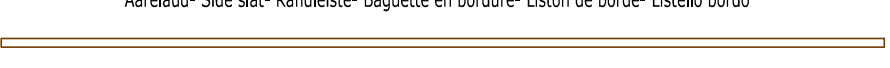
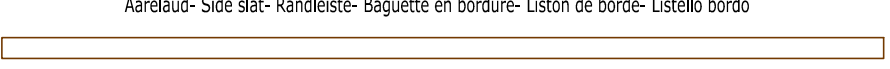
Pos	SPECIFICATION-STÜCKLISTE-NOMENCLATURE-ELEMENTI Grace_12.4m2+4.1m2	Pcs	Profile (mm)	Length (mm)
31	Log Plank 	1	56 x 350	2888
32	Log Plank 	1	56 x 535	2914
100	Katuselaud- Roof board- Dachbrett- Madrier du toit- Tavola tetto- Tabla de tejado 	9	89 x 19	2250
101	Pörandaliist- Floor beading- Fussbodenleiste- Baguette du plancher- Listello pavimento- Listón de suelo 	2	19 x 45	1457
102	Pörandaliist- Floor beading- Fussbodenleiste- Baguette du plancher- Listello pavimento- Listón de suelo 	4	19 x 45	2888
103	Pörandalaud- Floor board- Fussbodenbrett- Madrier du plancher - Tavola pavimento-Tabla de suelo 	25	114 x 28	1489
104	Alusraam- Foundation- Fundament- Fondation- Fondazione- Vigas de cimentación 	10	80 x 60	2830
105	Pörandaliist- Floor beading- Fussbodenleiste- Baguette du plancher- Listello pavimento- Listón de suelo 	2	19 x 45	2750
106	Pörandalaud- Floor board- Fussbodenbrett- Madrier du plancher - Tavola pavimento-Tabla de suelo 	25	114 x 28	2783
107	Katuselaud- Roof board- Dachbrett- Madrier du toit- Tavola tetto- Tabla de tejado 	9	89 x 19	3730
108	Katuse äär- Eave edging- Dachrandbrett- Madrier en bordure du toit- Tavola bordo tetto- Tabla de valadizo 	1	19 x 95	2780
109	Katuse roov- Roof edge reinforcement- Dachrandleiste- Baguette en bordure du toit- Rinforzo bordo tetto- Refuerzo borde tejado 	2	45 x 45	2990
110	Katuselaud- Roof board- Dachbrett- Madrier du toit- Tavola tetto- Tabla de tejado 	68	89 x 19	3260
112	Sarikas- Rafter- Sparre- Chevron- Trave- Cabrio 	7	44 x 140	1350
113	Katuse äär- Eave edging- Dachrandbrett- Madrier en bordure du toit- Tavola bordo tetto- Tabla de valadizo 	1	19 x 95	3200
114	Katuse katteliist- Covering board- Deckbrett- Madrier de couverture- Tavola di copertura- Listón de cubierta 	1	19 x 70	2270
115	Katuse äär- Eave edging- Dachrandbrett- Madrier en bordure du toit- Tavola bordo tetto- Tabla de valadizo 	2	18 x 150	3010
116	Sarikas- Rafter- Sparre- Chevron- Trave- Cabrio 	1	44 x 140	1350
117	Sarikas- Rafter- Sparre- Chevron- Trave- Cabrio 	1	44 x 140	1350
118	Katuse katteliist- Covering board- Deckbrett- Madrier de couverture- Tavola di copertura- Listón de cubierta 	2	19 x 70	4015
119	Katuse katteliist- Covering board- Deckbrett- Madrier de couverture- Tavola di copertura- Listón de cubierta 	1	19 x 70	3750
120	Katuse äär- Eave edging- Dachrandbrett- Madrier en bordure du toit- Tavola bordo tetto- Tabla de valadizo 	2	18 x 150	4080
121	Pärilin- Purlin- Dachpfette- Arbalétrier- Arcareccio- Vigueta de tejado 	3	56 x 180	5980
122	Pärilin- Purlin- Dachpfette- Arbalétrier- Arcareccio- Vigueta de tejado 	1	56 x 180	5980

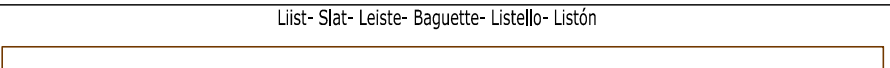



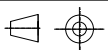







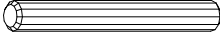

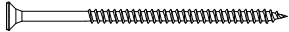
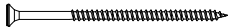

Pos	SPECIFICATION-STÜCKLISTE-NOMENCLATURE-ELEMENTI Grace_12.4m2+4.1m2	Pcs	Profile (mm)	Length (mm)
123	Nurgapost- Post- Pfosten- Poteau- Montante- Poste 	1	90 x 90	2400
124	T-Post- Tender post- Tenderleiste- T-poste- Rinforzo- Refuerzo 	2	38 x 56	2020
125	T-Post- Tender post- Tenderleiste- T-poste- Rinforzo- Refuerzo 	6	38 x 56	1592
131	Nurgapost- Post- Pfosten- Poteau- Montante- Poste 	1	90 x 90	2400
132	Nurgapost- Post- Pfosten- Poteau- Montante- Poste 	1	90 x 90	2117
133	Nurgapost- Post- Pfosten- Poteau- Montante- Poste 	1	90 x 90	2142
134	Alusraam- Foundation- Fundament- Fondation- Fondazione- Vigas de cimentación 	1	80 x 60	5730
135	Alusraam- Foundation- Fundament- Fondation- Fondazione- Vigas de cimentación 	1	80 x 60	4440
136	Support brace 	1	28 x 28	2355
137	Support brace 	1	28 x 28	2110
138	Äärelaud- Side slat- Randleiste- Baguette en bordure- Listón de borde- Listello bordo 	2	95 x 19	800
139	Äärelaud- Side slat- Randleiste- Baguette en bordure- Listón de borde- Listello bordo 	12	70 x 19	1670
140	Äärelaud- Side slat- Randleiste- Baguette en bordure- Listón de borde- Listello bordo 	6	70 x 19	570
141	Äärelaud- Side slat- Randleiste- Baguette en bordure- Listón de borde- Listello bordo 	2	95 x 19	990
142	Äärelaud- Side slat- Randleiste- Baguette en bordure- Listón de borde- Listello bordo 	4	70 x 19	2008
143	Lävepakk- Door Threshold- Türschwelle- Seuil de porte- Umbral dela puerta 	1	56 x 28	830
144	Äärelaud- Side slat- Randleiste- Baguette en bordure- Listón de borde- Listello bordo 	4	70 x 19	1980
145	Äärelaud- Side slat- Randleiste- Baguette en bordure- Listón de borde- Listello bordo 	6	95 x 19	800
146	T-Post- Tender post- Tenderleiste- T-poste- Rinforzo- Refuerzo 	2	38 x 56	2020
147	Liist- Slat- Leiste- Baguette- Listello- Listón 	6	56 x 19	1560
148	Liist- Slat- Leiste- Baguette- Listello- Listón 	6	56 x 19	598
149	Liist- Slat- Leiste- Baguette- Listello- Listón 	1	56 x 19	798
150	Liist- Slat- Leiste- Baguette- Listello- Listón 	2	56 x 19	1980

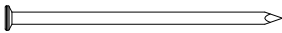
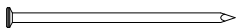

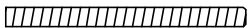



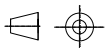

Object name

Grace_12.4m2+4.1m2

Page 3 / 5

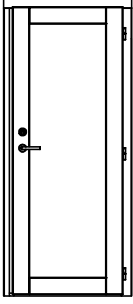
Pos	SPECIFICATION-STÜCKLISTE-NOMENCLATURE-ELEMENTI GRACE_12.4M2+4.1M2	Pcs	Code/ Profile	Info
F1	TÜÜBEL- DOWEL- DÜBEL- CHEVILLE- TASSELLO- ESPIGA- QTY16X130 	130	QTY16x130 16x16x130	To Log Planks
F2	TIHEND- SEAL- DICHTUNG- JOINT D'ISOLATION- GUARNIZIONE- BURLETE- QTI15 	10	QTI15 15x15x10000	To Log Planks
F3	TIHEND- SEAL- DICHTUNG- JOINT D'ISOLATION- GUARNIZIONE- BURLETE- QTI40 	2	QTI40 40x40x2100	To top of doors & windows
F4	KRUVI- SCREW- SCHRAUBE- VIS- VITE- TORNILLO- 6X120MM 	156	QKRPP6x120ZnTx ø6 x 120	20 to foundation, 76 to Log Planks, 36 to rafters, 24 to purlins
F5	KRUVI- SCREW- SCHRAUBE- VIS- VITE- TORNILLO- 4.5X70MM 	26	QKRPP4_5x70TxZn ø4.5 x70	16 to corner slats;10 to T-posts
F6	KRUVI- SCREW- SCHRAUBE- VIS- VITE- TORNILLO- 4.5X50MM 	248	QKRPP4_5x50TxZn ø4.5 x50	50 to floor beading;12 to louver;112 to roof slats;74 to door/window slats
F7	KRUVI- SCREW- SCHRAUBE- VIS- VITE- TORNILLO- 5X40MM 	8	QKRYP5x40ZnTX ø5 x 40	to L-iron 50x65x130
F8	Screw- Schraube- Vis- Vite- Tornillo- 3.5x16mm ZnY 	8	QKRYP3_5x16Zn	to L-iron 50x65x130
F9	NAEL- NAIL- NAGEL- CLOU- CHiodo- CLAVO- 3X70MM 	250	QNA3x70ZN	To floor board
F10	NAEL- NAIL- NAGEL- CLOU- CHiodo- CLAVO- 2,2X50MM 	550	QNA2.2x50ZN	To roof board
F11	Keermelatt- Threaded rod- Gewindestangen- Barre fileée- Asta filettata- Varilla roscada M8 	4	QKE8 ø8 x 2000	To walls
F12	Keermelatt- Threaded rod- Gewindestangen- Barre fileée- Asta filettata- Varilla roscada M8 	2	QKE8 ø8 x 300	To walls
F13	MUTTER- NUT- SCHRAUBENMUTTER- ÉCROU- DADO- TUERCA- M8MM 	4	QMUKK8Zn M8	To walls
F14	SEIB- WASHER- DICHTSCHEIBE- JOINT- RONDELLA- ARANDELA- 8X20MM 	4	QSE8x20Zn ø8 x 20	To walls
F15	JÄTKUMUTTER- EXTENSION NUT- VERLÄNGERUNGSMUTTER- ÉCROU RALLONGE- DADO DI PROLUNGA- TUERCA DE EXTENSIÓN 	4	QMUJ8Zn	To walls
F16	LÖÖGIMUTTER- CAPTIVE NUT- EINSCHLAGMUTTER- ÉCROU A GRIFFES- DADO A RAGNO FILETTATURA- TUERCA ARANA- LM8 	4	QMULG8Zn	To walls
F17	AVA KATE- COVERING CAP - ABDECKKAPPE - COUVERCLE - COPERTURA- CUBIERTA 	4	QKA85	To walls

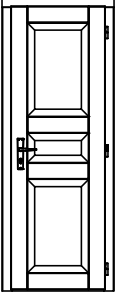
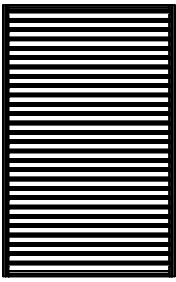

Pos	SPECIFICATION-STÜCKLISTE-NOMENCLATURE-ELEMENTI GRACE_12.4M2+4.1M2	Pcs	Code/ Profile	Info
F18	VEEPLERK- DETAIL- DETAIL- DETTAGLIO- DETALLE 	3	QP40x0_5x600MU 40 x 0,5 x 600	To windows
F19	L-iron- Winkel- Angle -Angolo- Angulo QNU50x65x130Zn 	2	QNU50x65x130Zn	To louver
U00-64P	Uks- Door - Tür - Porte - Porta-Puerta 760 x 1980 	1		
A00-9P	Aken- Window - Fenster - Fenetre - Finestra-Ventana 560 x 1560 	3		
U56-2P	Uks- Door - Tür - Porte - Porta-Puerta 700 x 2000 	1		
	žaluzii- Louver- das Lattenfenster- la persienne- la persiana 70 x 1190 x 1880 mm 	1		
 				
Object name GRACE_12.4M2+4.1M2			Page 5 / 5	

5730

1290

80

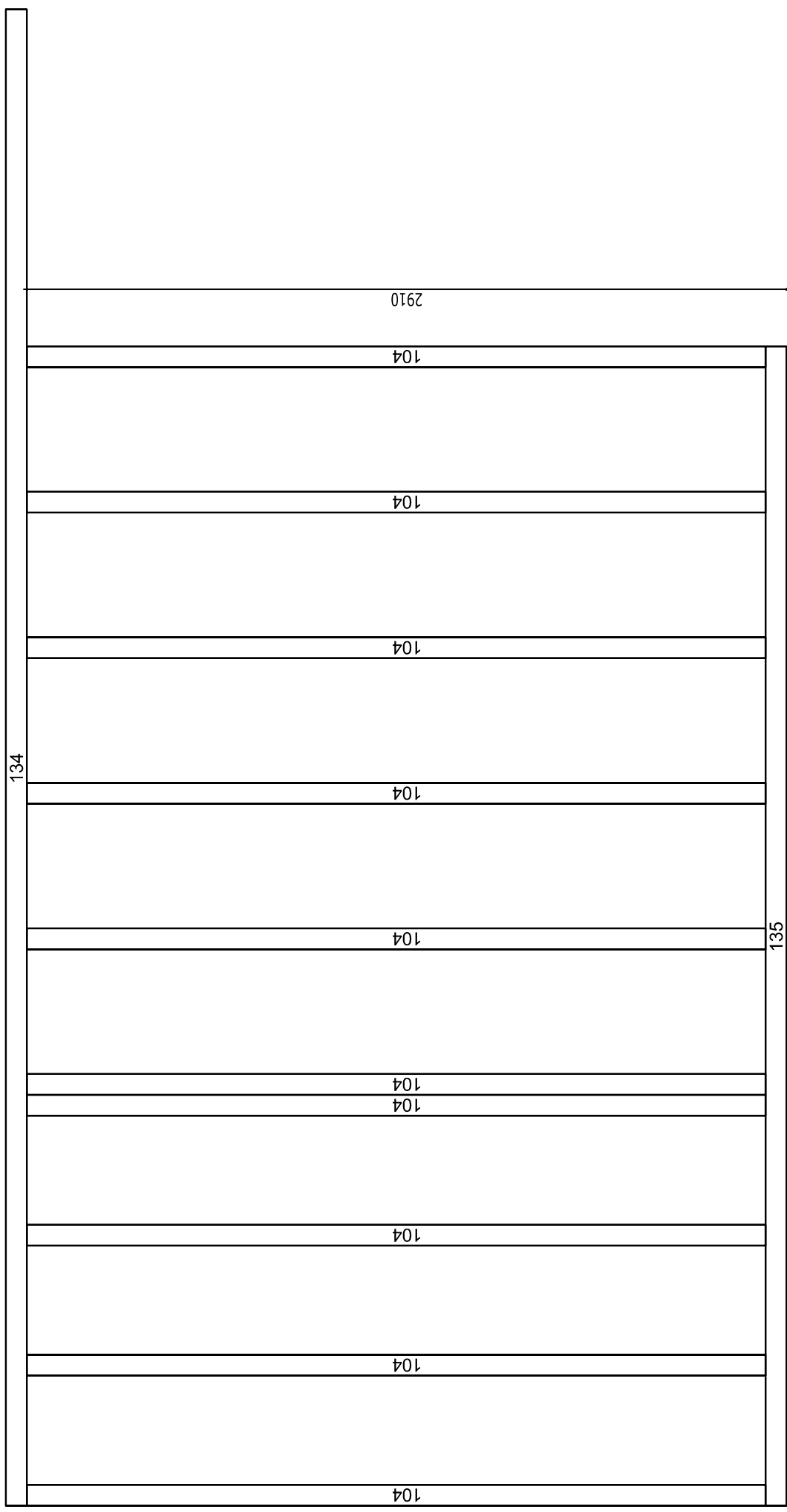

2990

80

80

418

418

80

418

160

418

477

80

477

80

4440

Grace 12.4+4.1 Plan

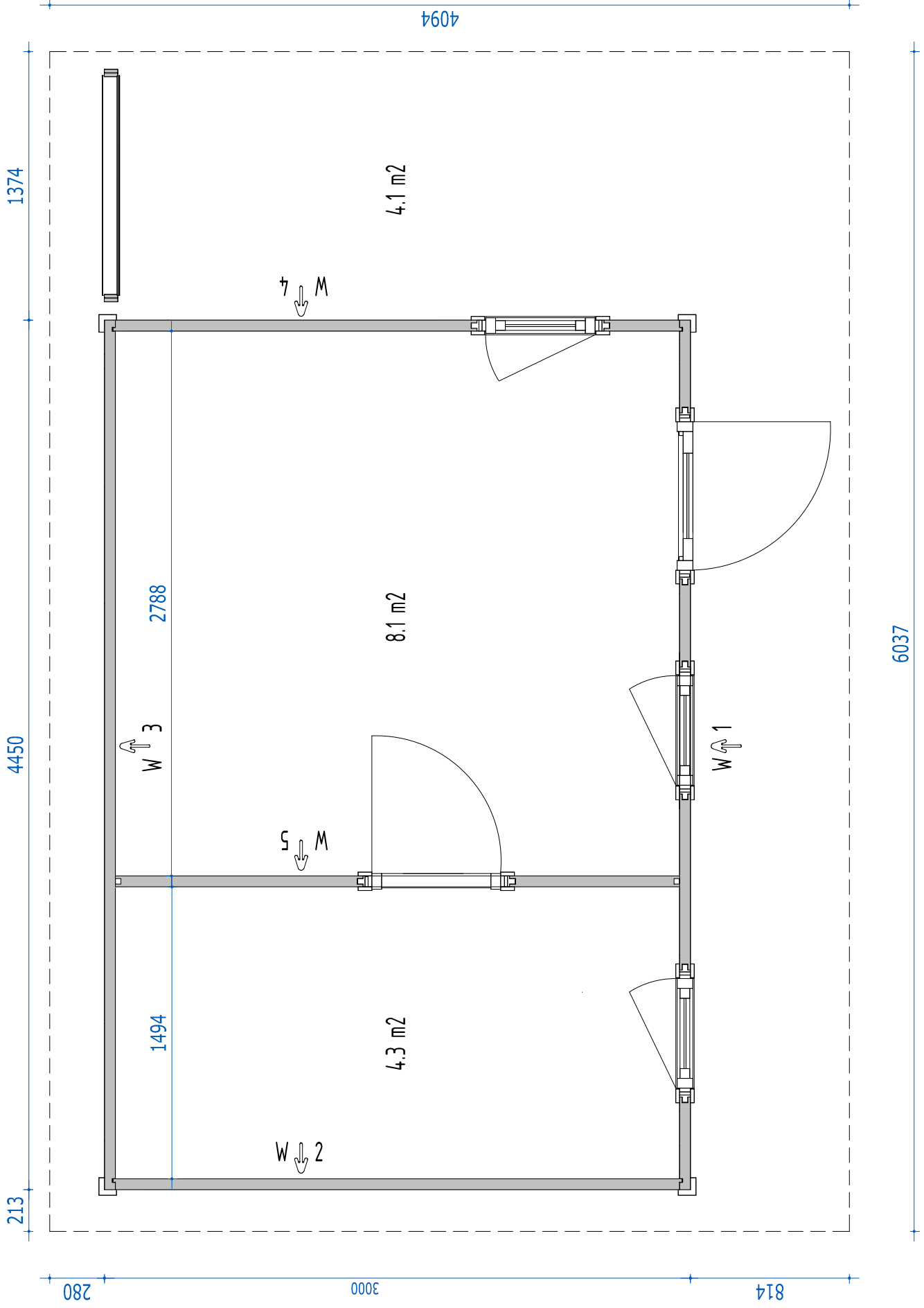

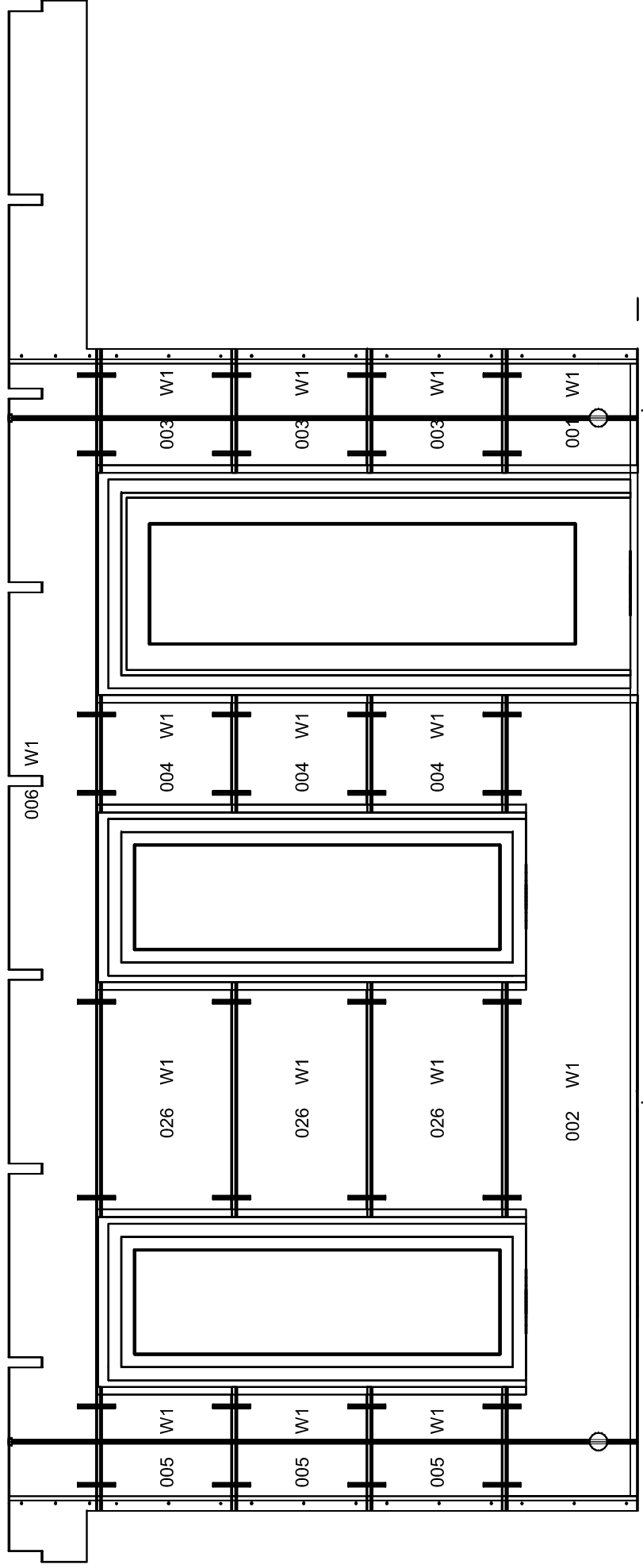

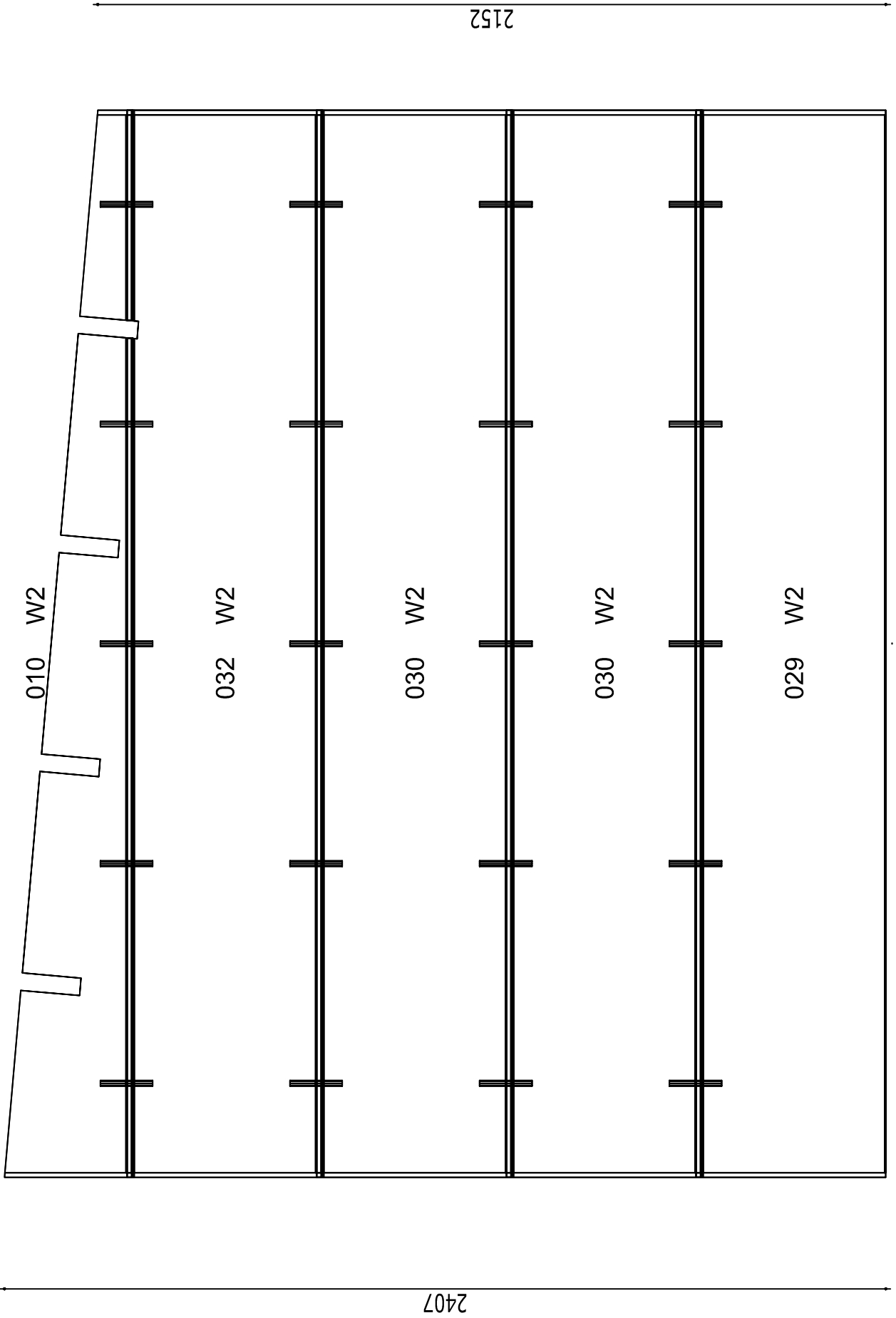

5980

014 W3

013 W3

012 W3

012 W3

011 W3

2153

4450

1335

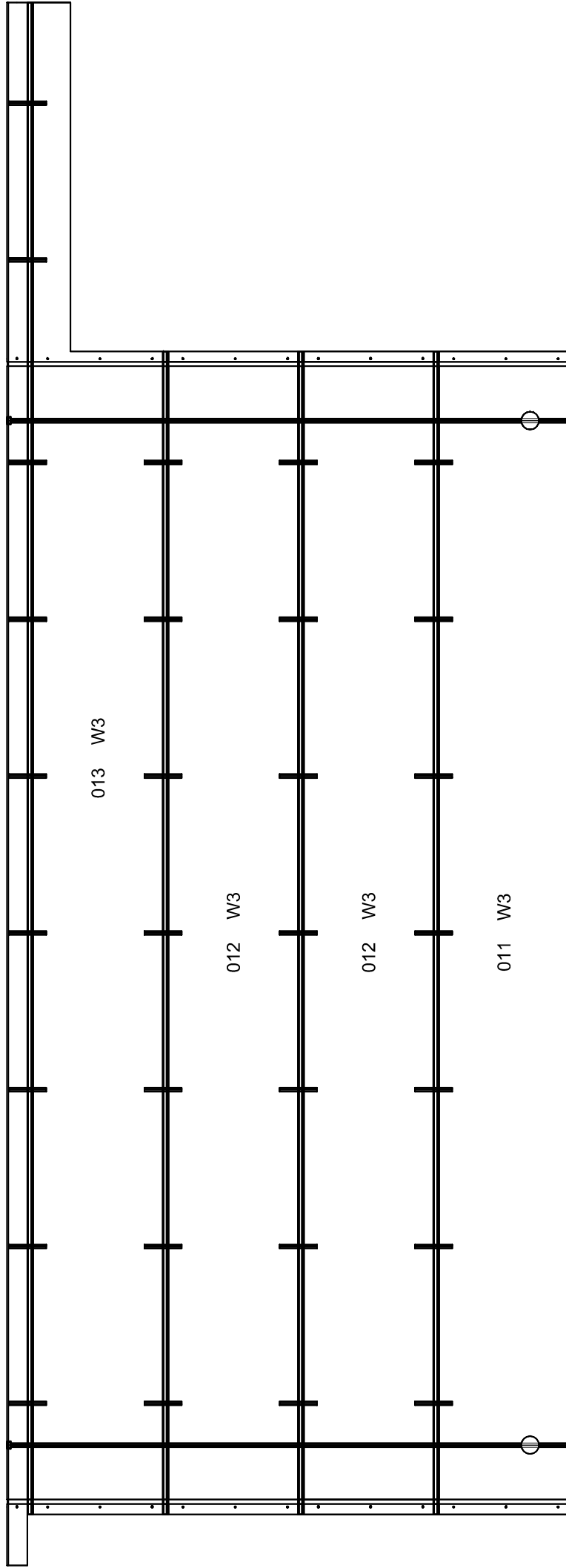

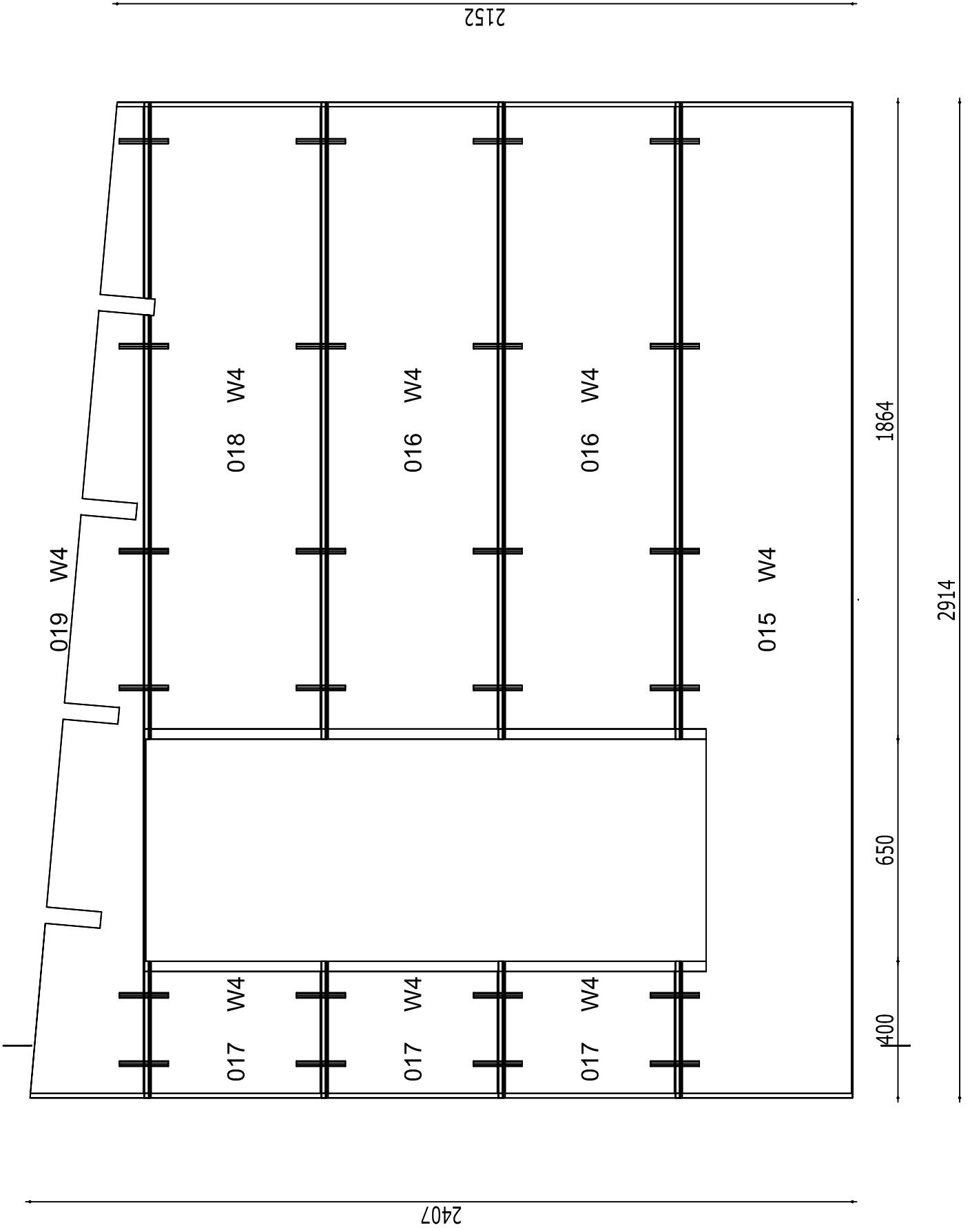

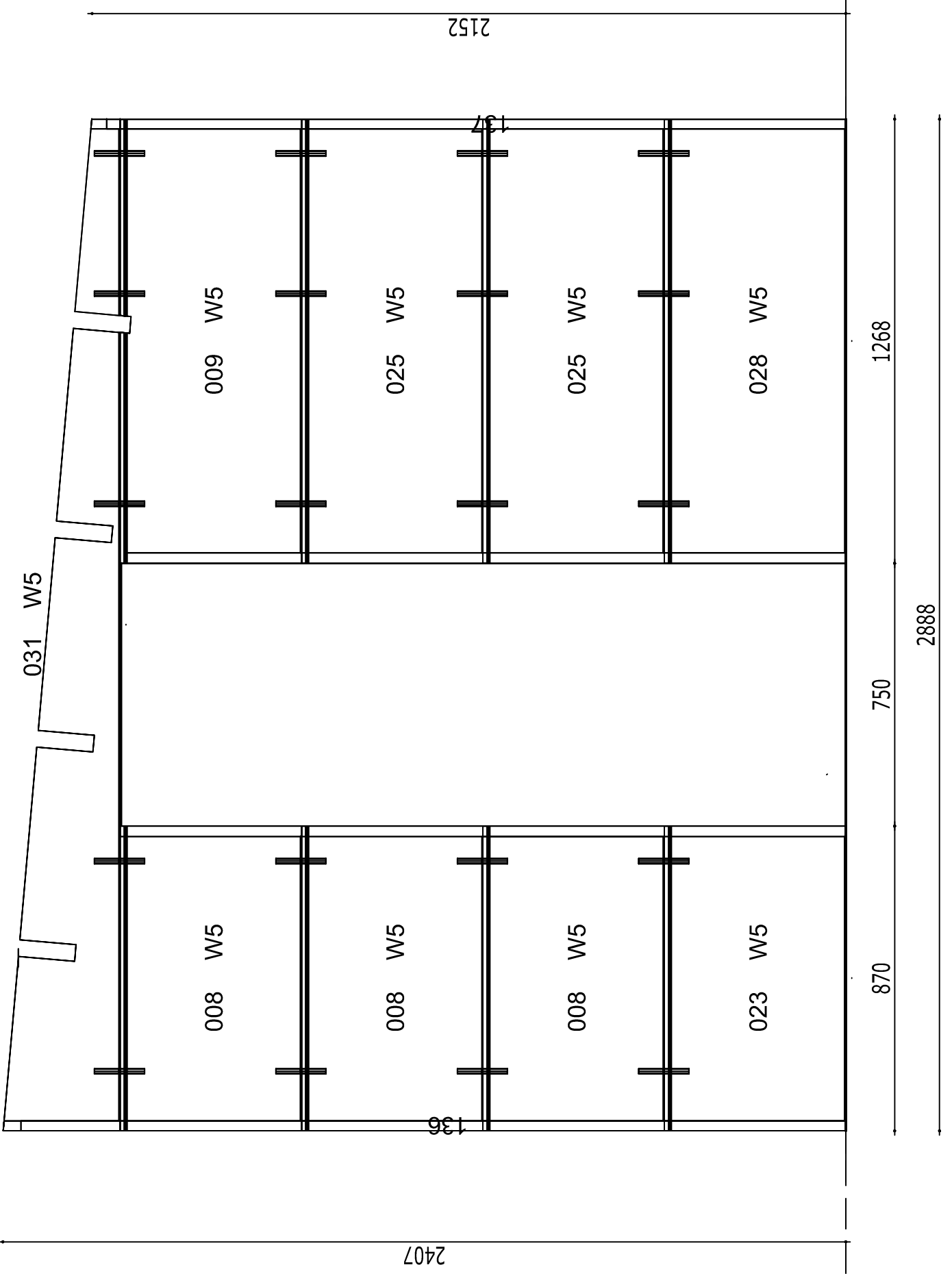



Object name	T04525_MODERNLOOK_ODE_II		
AS Palmako	Näiteuse 25, Tartu, 50409, Estonia		
LEMEKS GROUP	tel. +372 73 55 530		
	fax. +372 73 55 544		
	www.palmako.com		
Scale	1:40	Drawing	Vaated
Paper	A3	Drawn by	007
		Checked by	
		Approved by	
		Date	02.07.2019
		Date	
		Date	
Page	1		

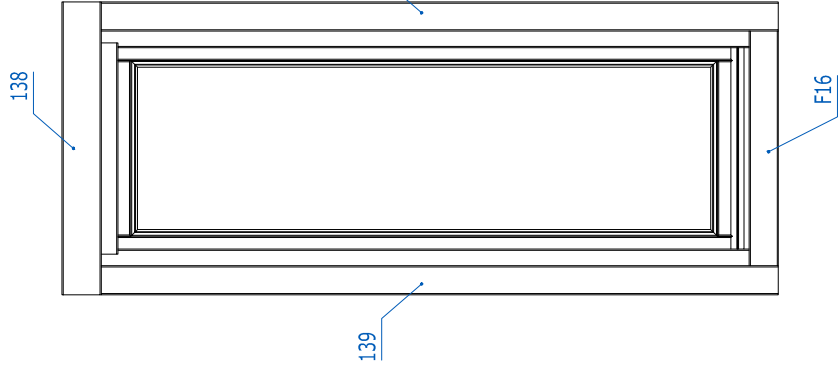

A00-9P - 3 pcs

Window
560 x 1560 x 56 mm

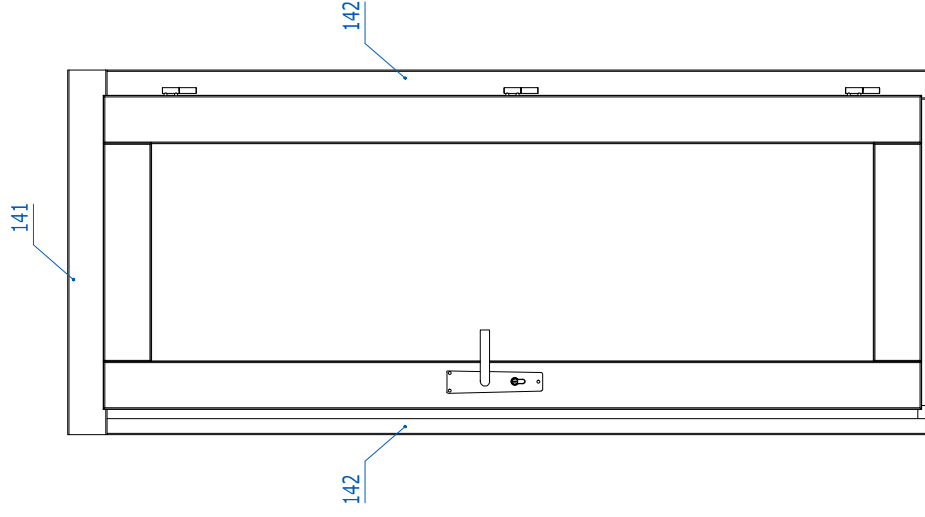

U00-64P - 1 pcs

Door
760 x 1980 x 56 mm

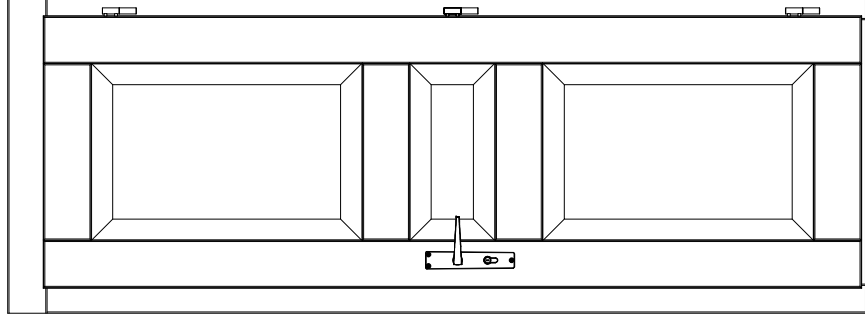

U56-2P - 1 pcs

Door
700x2000x56 mm

