

Installation manual

Montageanleitung • Notice de montage • Istruzioni per il montaggio
Manual de montaje • Monteringsanvisning • Installatiegids • Asennusohje • Installationsmanual • Paigaldusjuhend

Element house EL16-2419

Elementhaus • Maison à modules • Casetta in elementi • Cobertizo • Redskapsbod • Element huis • Elementti piharakennus • Friggebod • Elementmaja

Width 243 x Depth 190 cm

Breite/Tiefe • Largeur/Profondeur • Lunghezza/Profondità • Ancho/Profundidad • Bredd/Dybde • Breedte/Diepte • Leveys/Pituus • Bredd/Längd • Laidus/pikkus

Log thickness 16 mm

Bohlenstärke • Épaisseur des murs • Spessore delle pareti • Grosor de pared • Tykkelse • Wanddicke • Seinän paksuus • Väggtjocklek • Seinapaksus



The producer shall have the right to make technical changes to the product • Technische Änderungen vorbehalten • Le producteur réserve le droit d'effectuer des modifications techniques au produit • Il produttore mantiene il diritto di apportare modifiche tecniche al prodotto • Reservado el derecho a modificaciones técnicas • Produsent forbeholder seg retten til å endre tekniske egenskaper ved produktet • Alle rechten en technische wijzigingen voorbehouden • Valmistaja pidättää oikeuden tehdä tuotteeseen teknisiä muutoksia • Tillverkaren har rätt att utföra tekniska förändringar för produkten • Tootja jätab endale õiguse muuta toota tehnilisi omadusi

Specification • Stückliste • Liste des pièces détails • Lista degli elementi

Pos. Nr.	Description Beschreibung Description Descrizione	Measurements Masse Dimensions Misure	Amount Menge Quantités Quantità
1	Side wall panel Seitenwandelement Module du mur latéral Elemento parete laterale	1870*900*48 mm	3
2	Side wall panel with window Seitenwandelement mit Fenster Module du mur latéral avec fenêtre Elemento parete laterale con la finestra	1870*900*48 mm	1
3	Rear wall panel Rückwandelement Module du mur derrière Elemento parete posteriore	1870*800*48 mm	3
4	Front wall panel Vorderwandelement Module du mur devant Elemento parete anteriore	1870*505*48 mm	1+1
5	Apex Giebel Croupe Timpano	1180*366*48 mm	2+2
6	Connecting board for apex Verbindungsbrett für Giebel Pièce de liaison de la croupe Blocco di collegamento del pignone	292*40*32 mm	2
7	Batten for apex Leiste für Giebel Plinthe de la croupe Listello del timpano	275*95*16 mm	2
8	Door panel Türelement Module de la porte Elemento della porta	1865*700*48 mm	1+1
9	Middle purlin and side purlin (part) Firstpfette und Seitenpfette (Teil) Détail du chevron de la faîte et du chevron latéral Dettaglio della capriata centrale e laterale	1380*80*19 mm	4
10	Middle purlin and side purlin (part) Firstpfette und Seitenpfette (Teil) Détail du chevron de la faîte et du chevron latéral Dettaglio della capriata centrale e laterale	670*80*19 mm	4
11	Foundation joists Lagerhölzer Poutre du fondement Trave delle fondamenta	1200*40*32 mm	10
12	Connecting board for foundation joists Verbindungsholz für Lagerhölzer Pièce de liaison du fondement Blocco di collegamento delle fondamenta	430*40*32 mm	5
13	Floor boards Fussbodenbretter Planches pour le plancher Tavole pavimento	Ver. 1: 1864*89*16 mm Ver. 2: 1864*114*16 mm	27(+1) 21(+1)

14	Roof boards Dachbretter Planches du toit Assi del tetto	Ver. 1: 1350*89*16 mm Ver. 2: 1350*114*16 mm	46 36
15	Wall batten for front and rear wall, on the side Wandleiste für Vorder- und Rückwand, seitlich Plinthe latérale du mur d'avant et d'arrière Listello parete anteriore e posteriore, di lato	1900*95*16 mm	2+2
16	Wall batten for rear wall, middle Wandleiste für Rückwand, mittig Plinthe du mur d'arrière, au milieu Listello parete posteriore, al centro	1890*95*16 mm	2
17	Wall batten for side wall Wandleiste für Seitenwand Plinthe du mur latéral Listello parete laterale	1790*95*16 mm	6
18	Eave edging Traufenleiste Plinthe de la gouttière Listello della gronda	1025*45*16 mm	4
19	Roofing felt batten Dachpappeleiste Plinthe pour la couverture du toit Listello cartone catramato	1370*45*16 mm	4
20	Facia board Giebelblende Écran frontal Schermo frontone	1370*95*16 mm	2+2
21	Door batten Türleiste Plinthe de la porte Listello della porta	910*45*16 mm	2
22	Diamond Raute (Stirnbrettabdeckung) Losange (couvre la plinthe de la croupe) Rombo (copertura dell'asse del timpano)		2
	Roofing felt Dachpappe Couverture du toit Cartone catramato	OPTIONAL !!! 2100x1000 mm	3

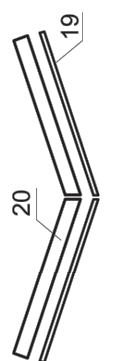
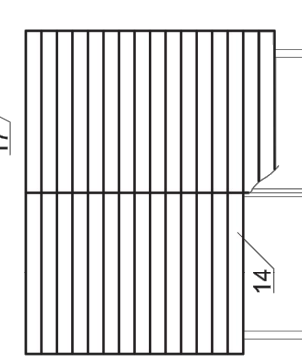
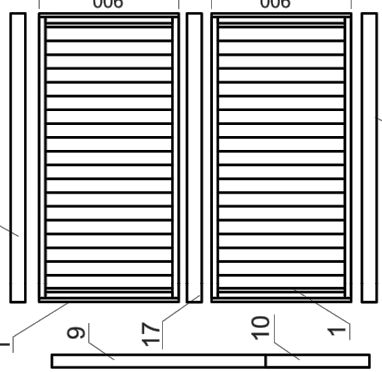
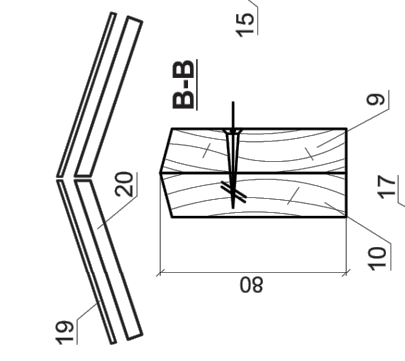
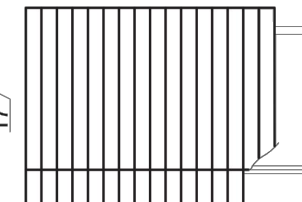
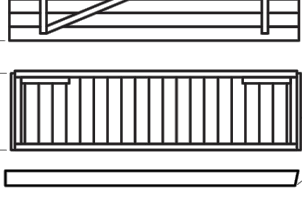
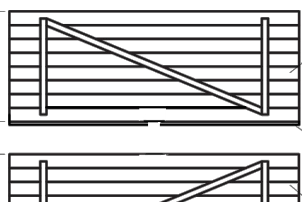
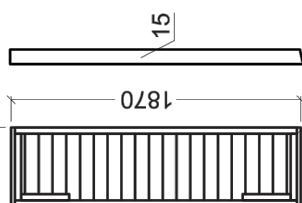
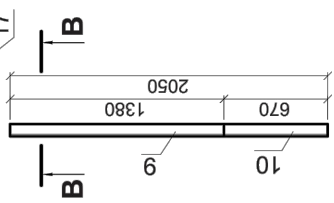
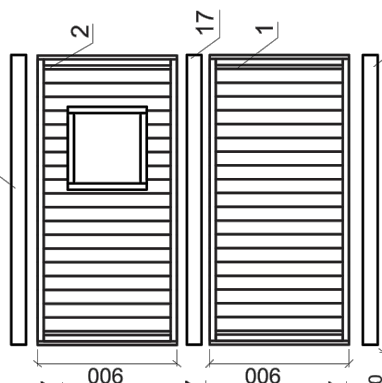
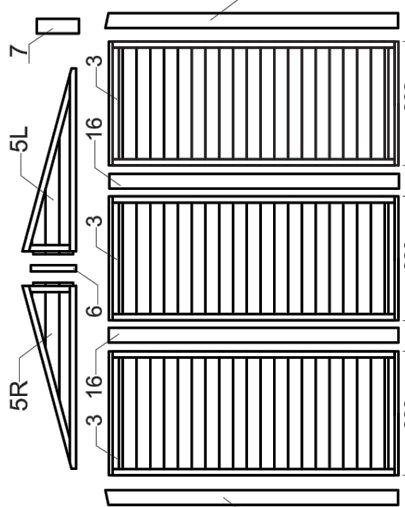
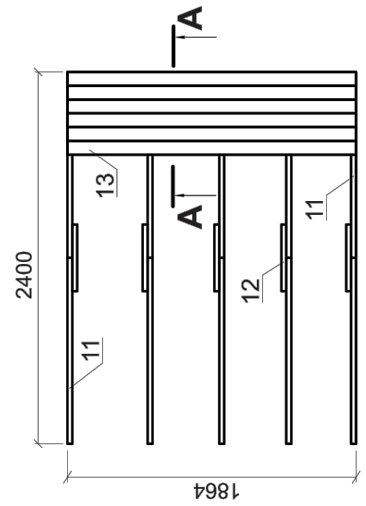
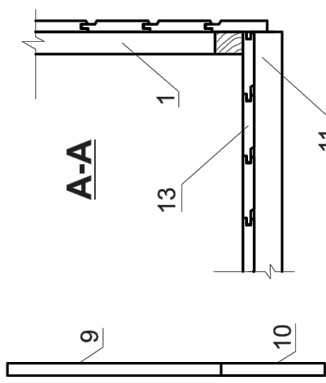
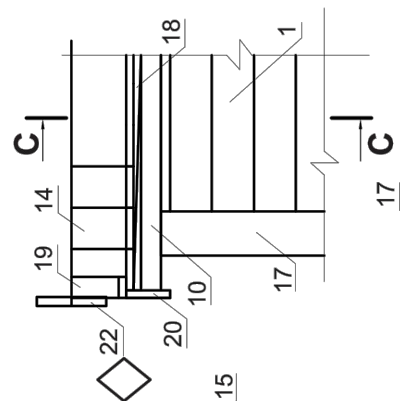
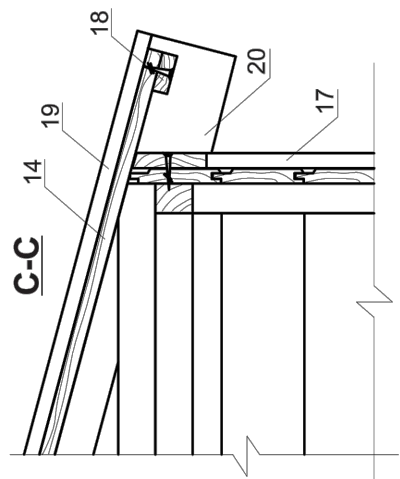

- A** Ø5x70 x 64 st.
- B** Ø4,5x60 x 20 st.
- C** Ø3,5x40 x 148 st.
- D** Ø3x35 x 20 st.
- E** Ø3x30 x 18 st.
- F** Ø3x16 x 24 st.
- G** Ø2,5x20 x 100 st.
- H** Ø2,5x50 x 230 st.

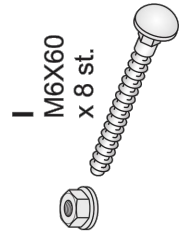

L
x 1 st.

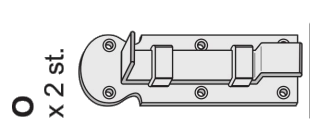
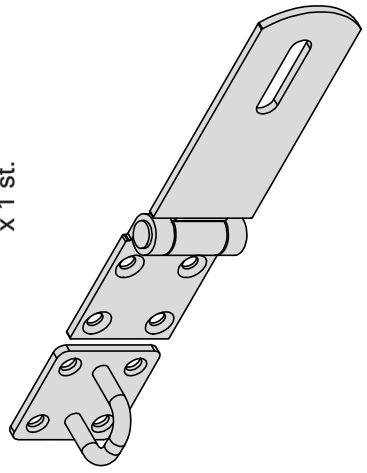

O
x 2 st.

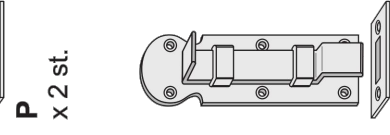

P
x 2 st.

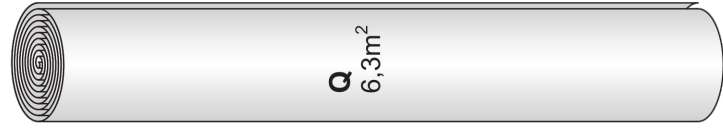

Q
6,3m²

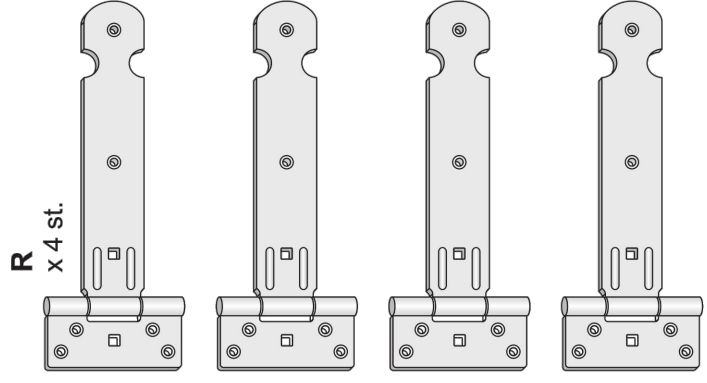

R
x 4 st.

OPTIONAL !!!

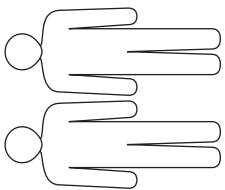

Ø6

Ø3

M10

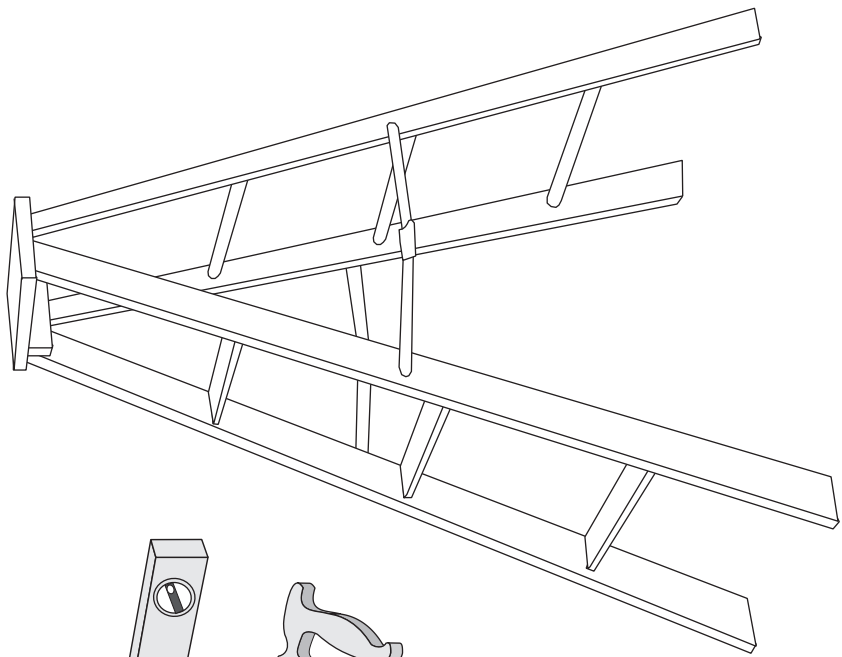
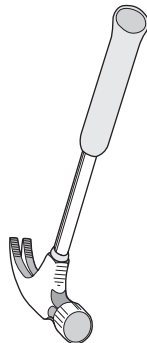
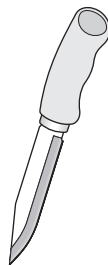
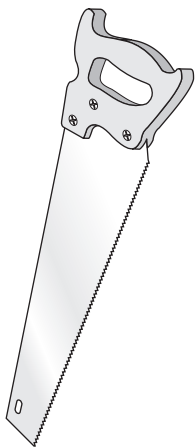
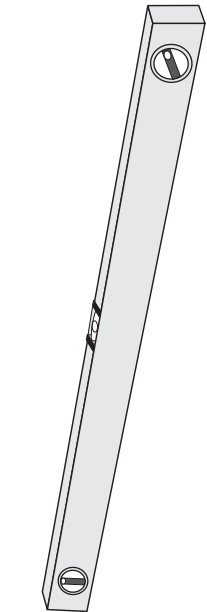
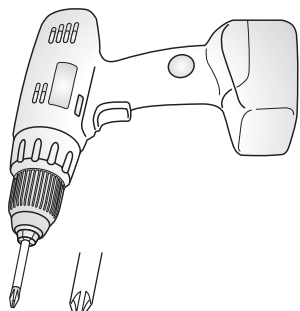
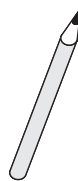
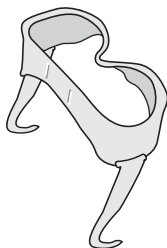
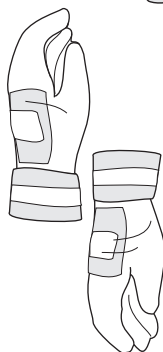
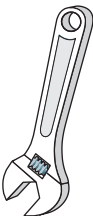

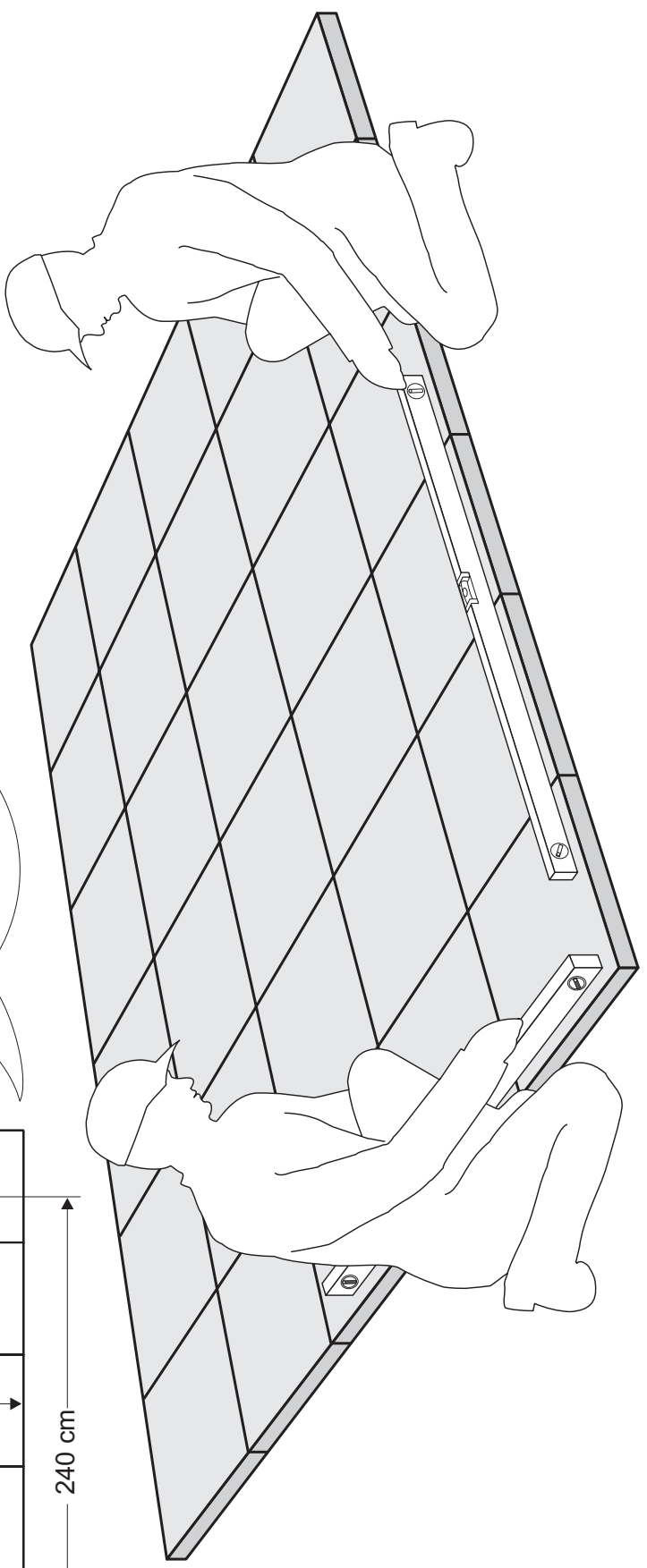
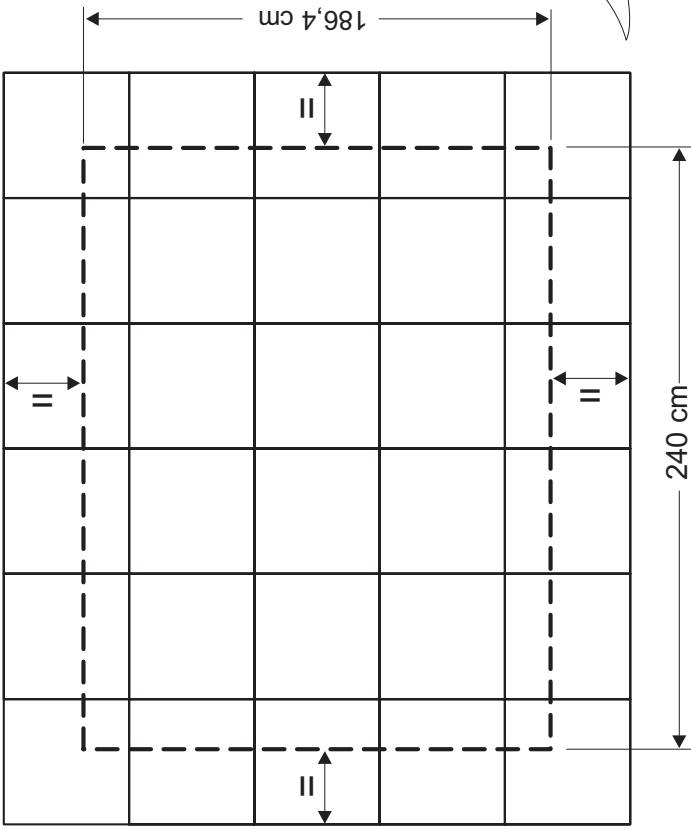
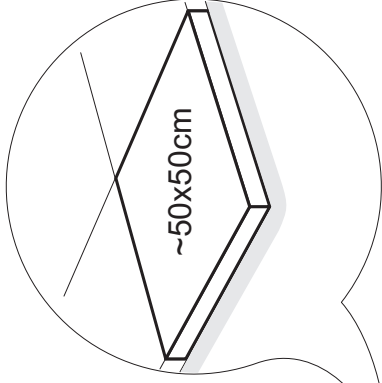
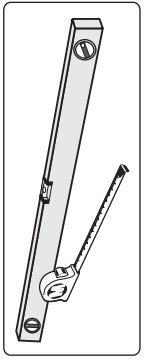

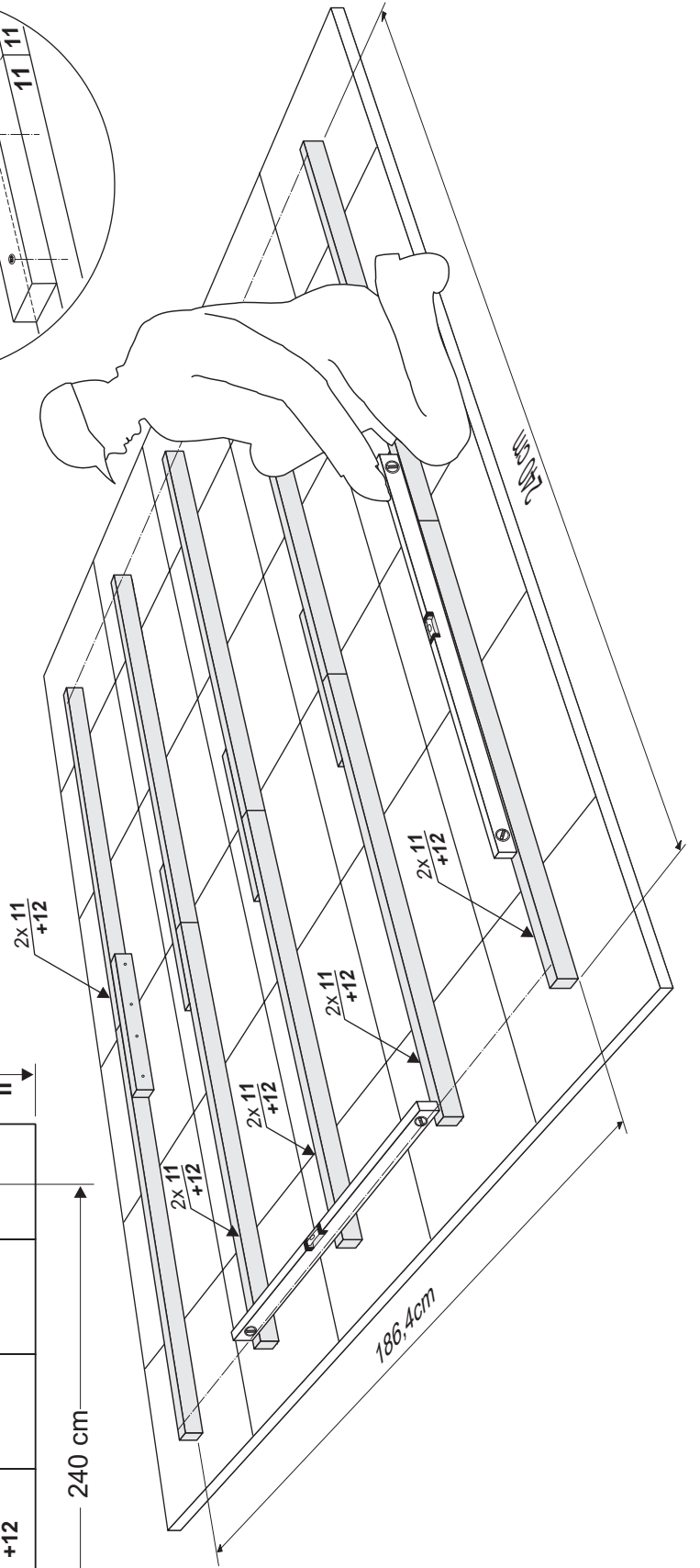
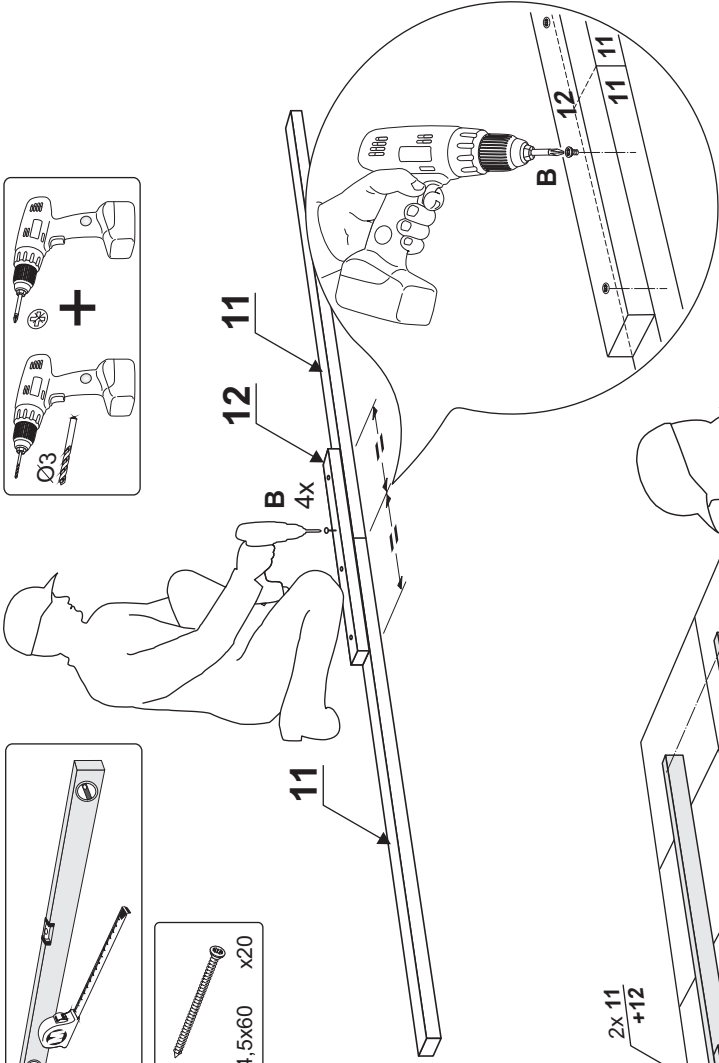
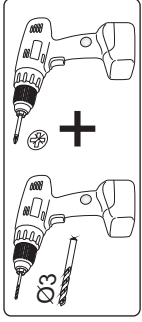
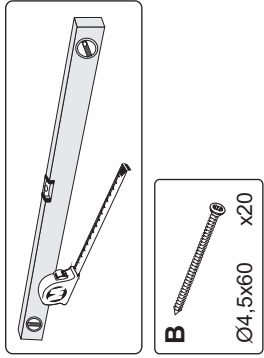
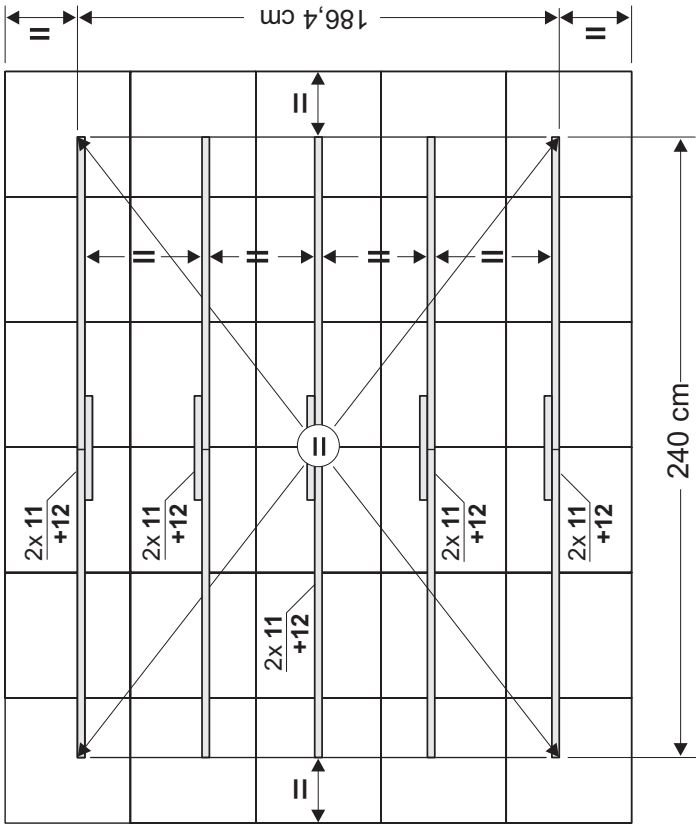

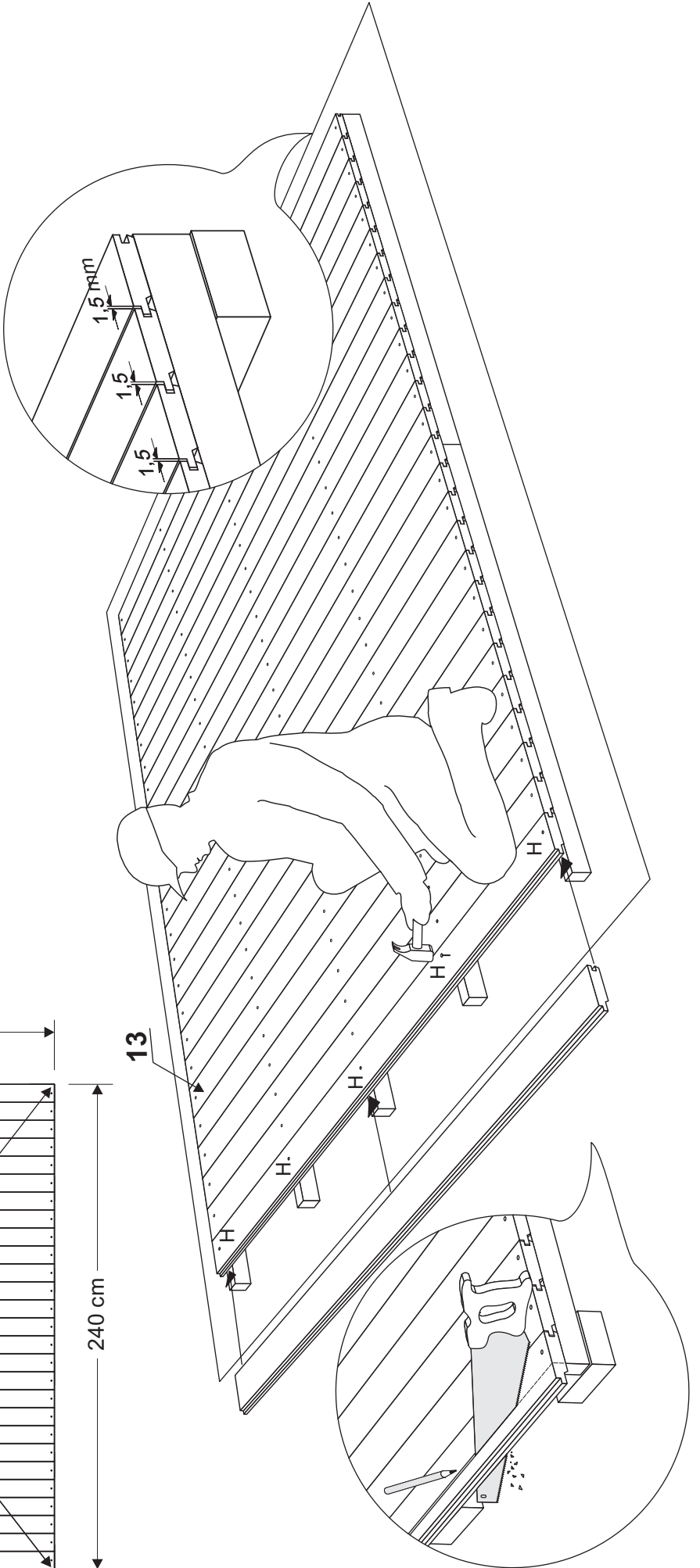
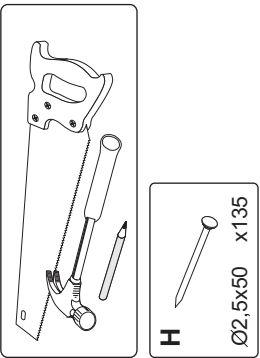
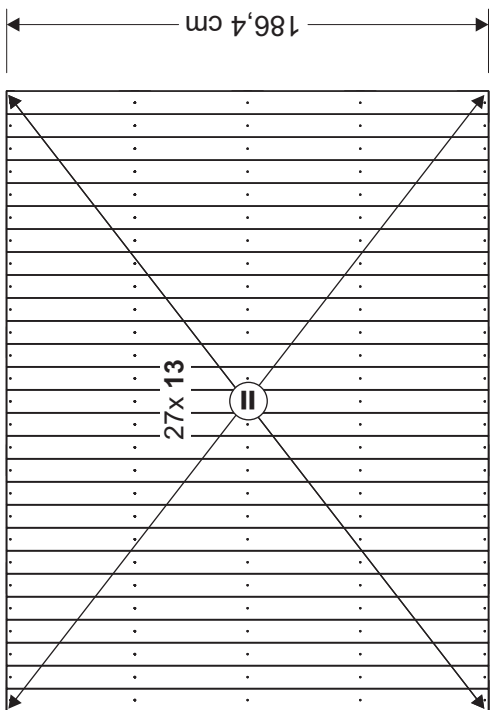

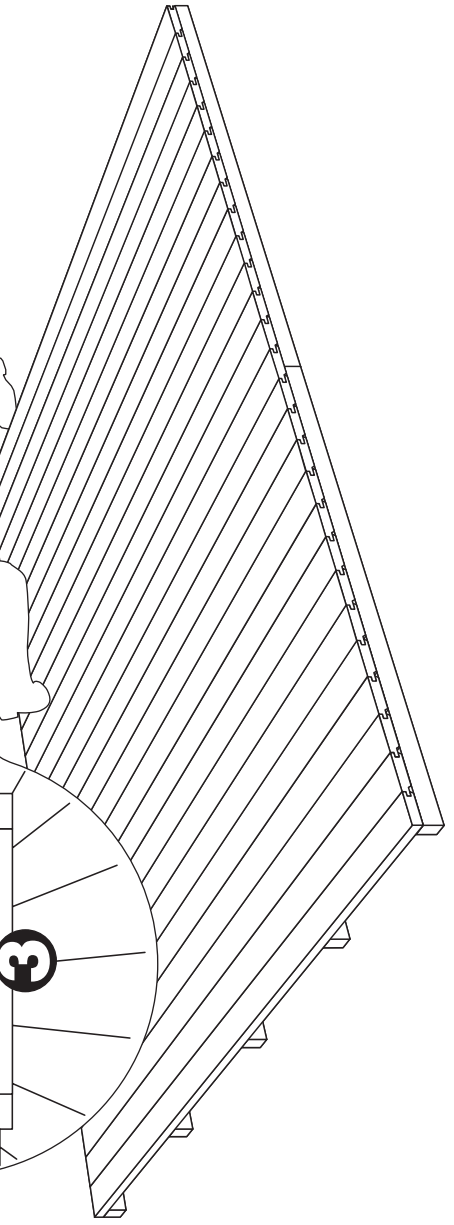
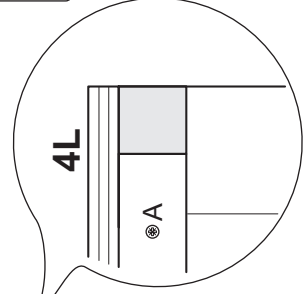
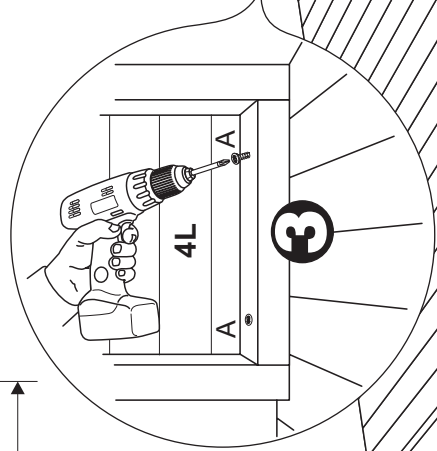
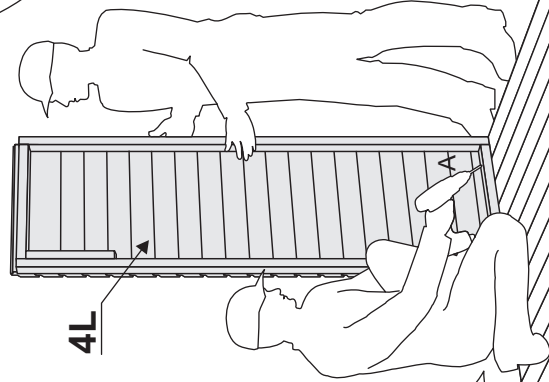
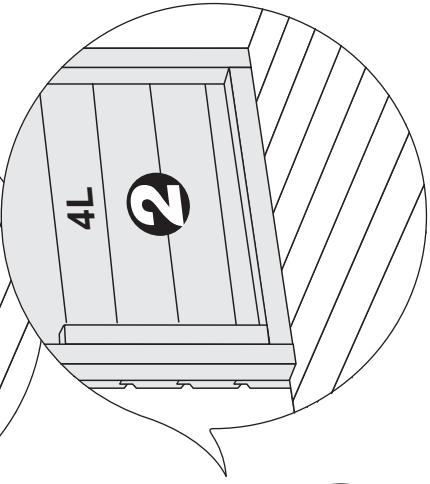
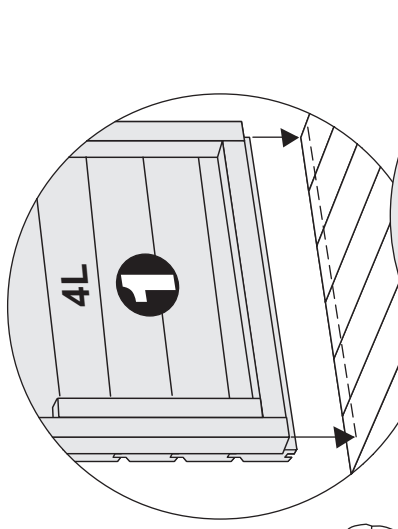
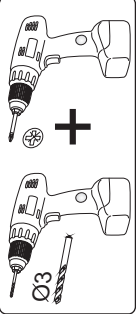
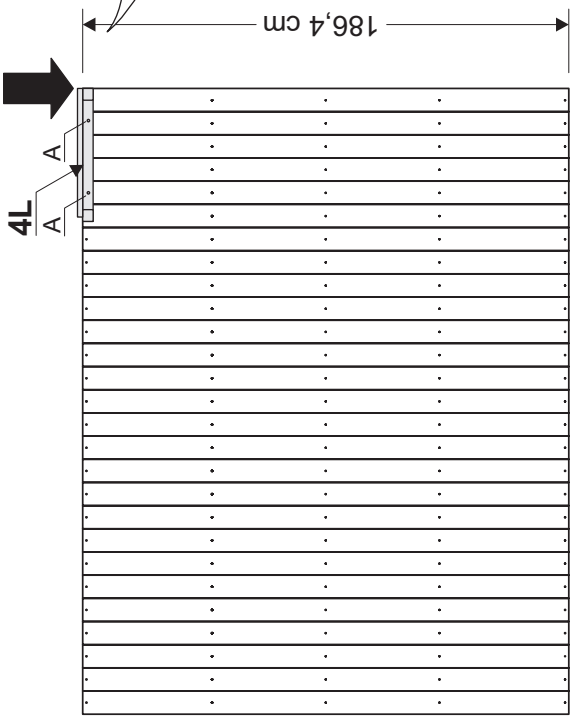

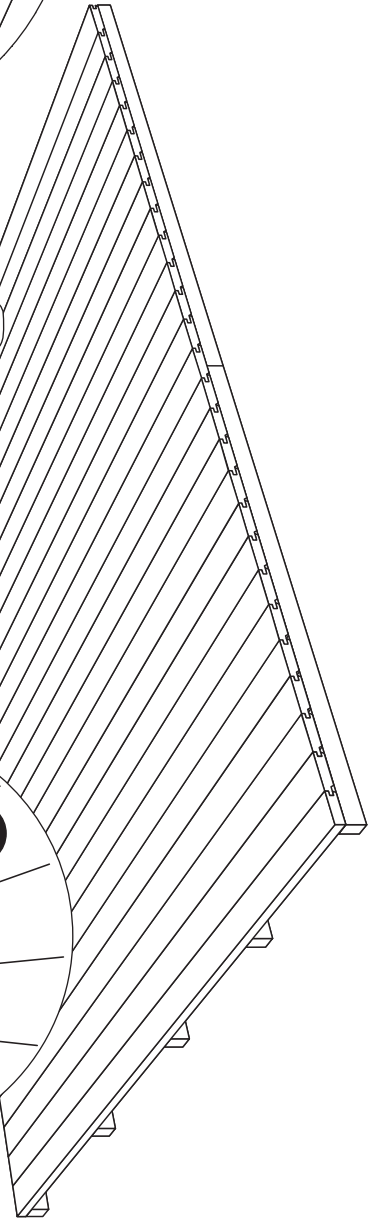
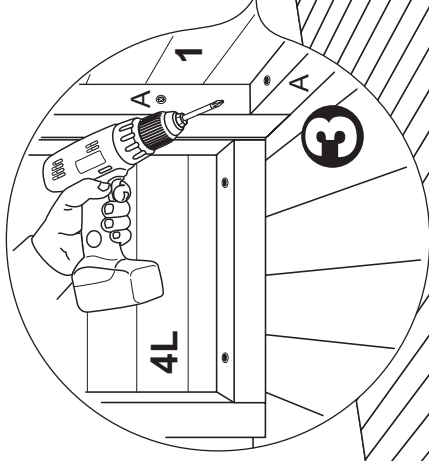
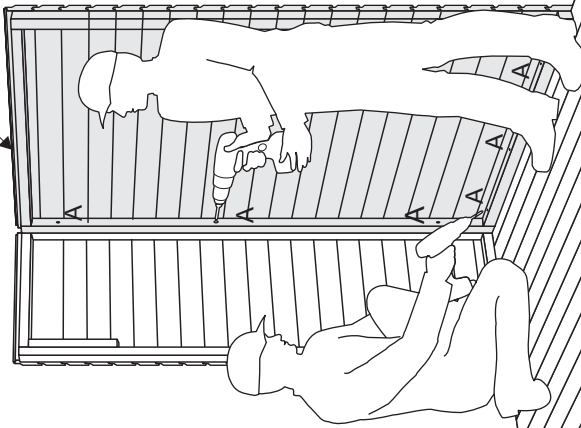
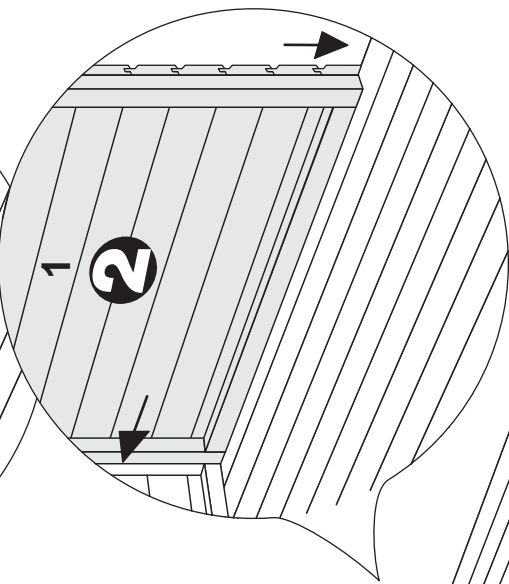
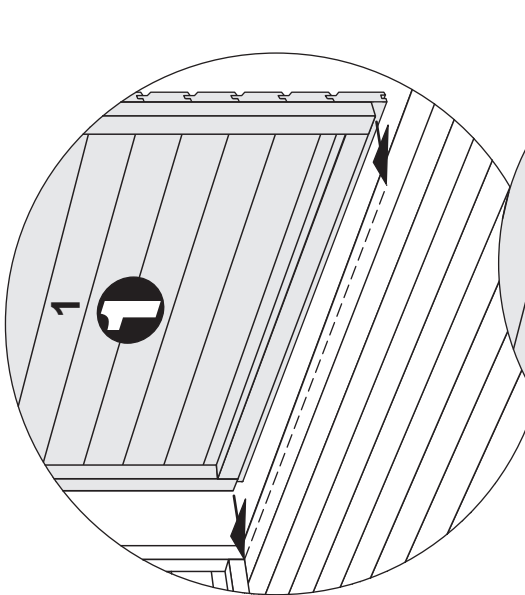
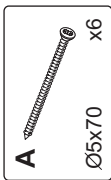
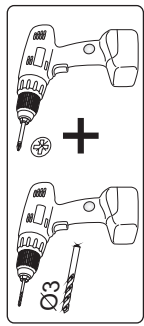
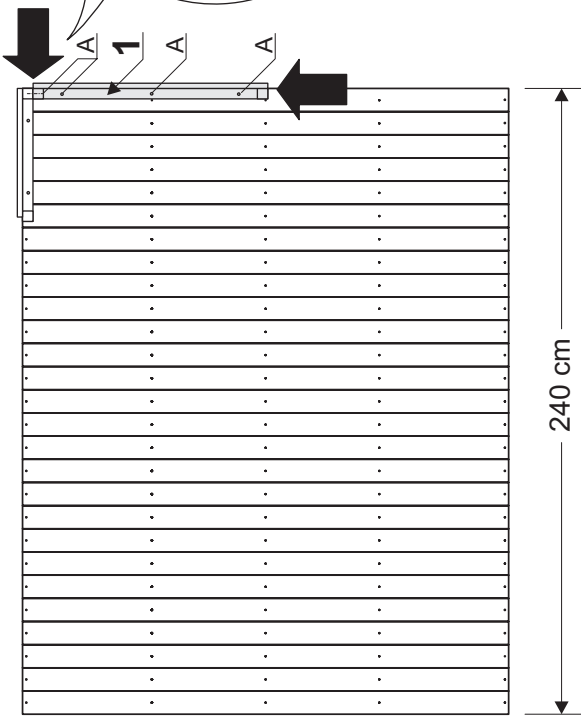

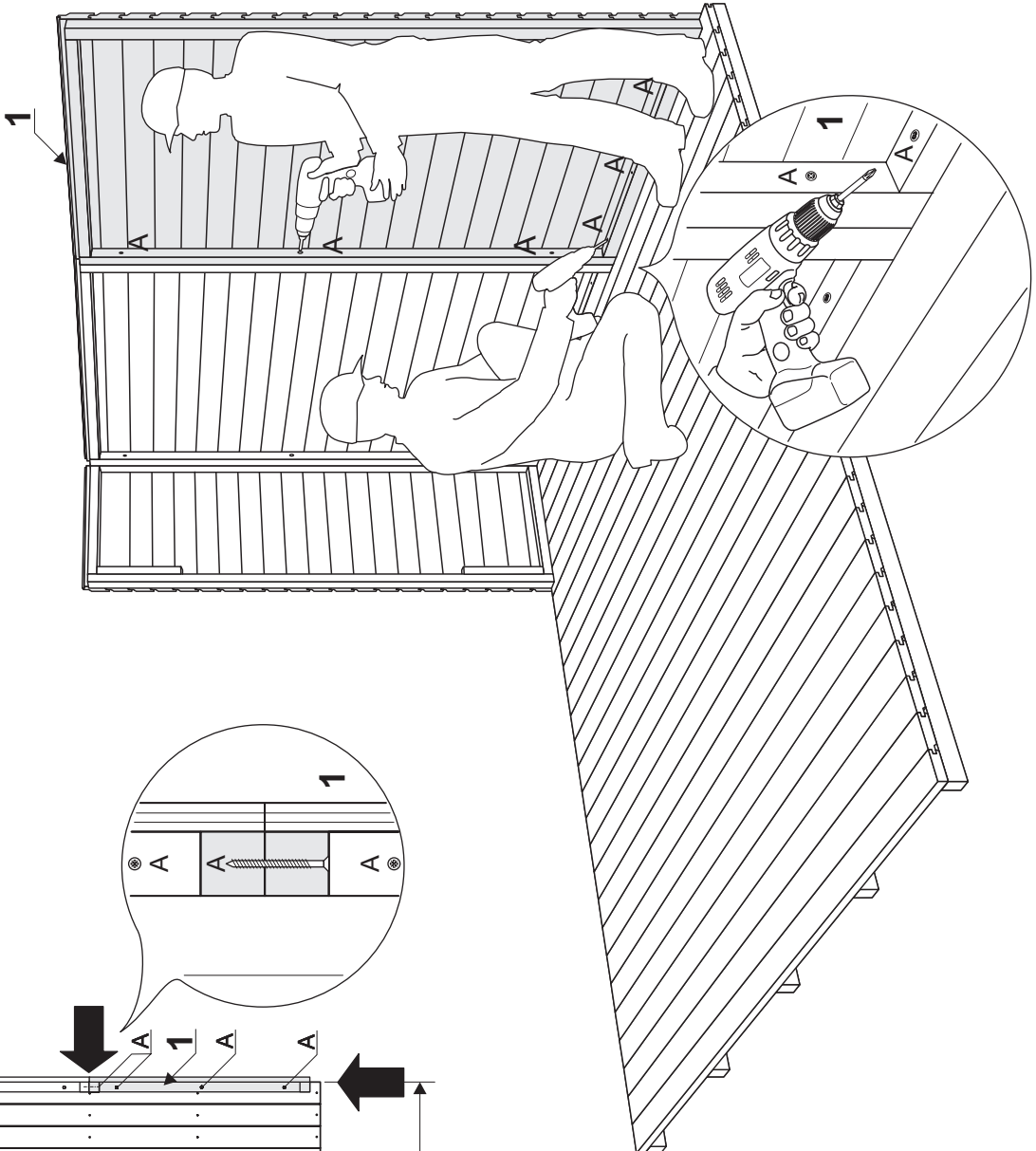
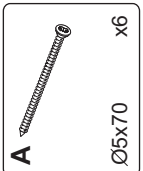
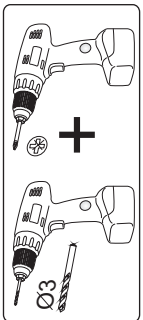
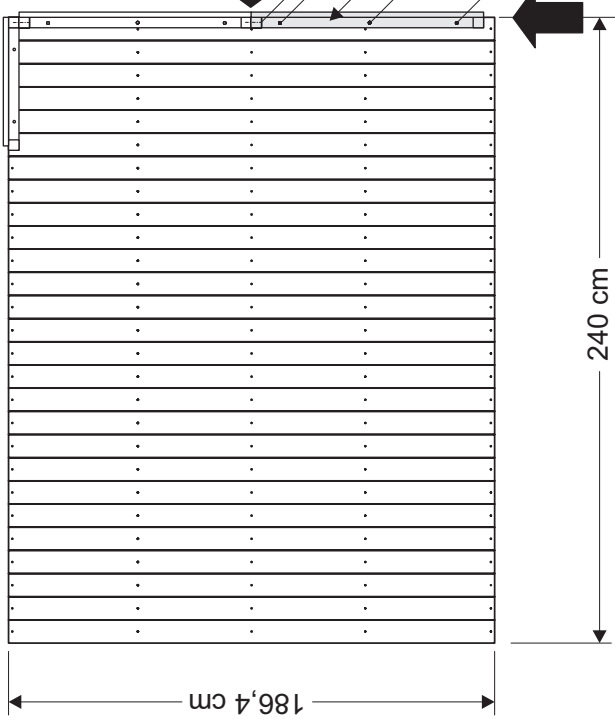

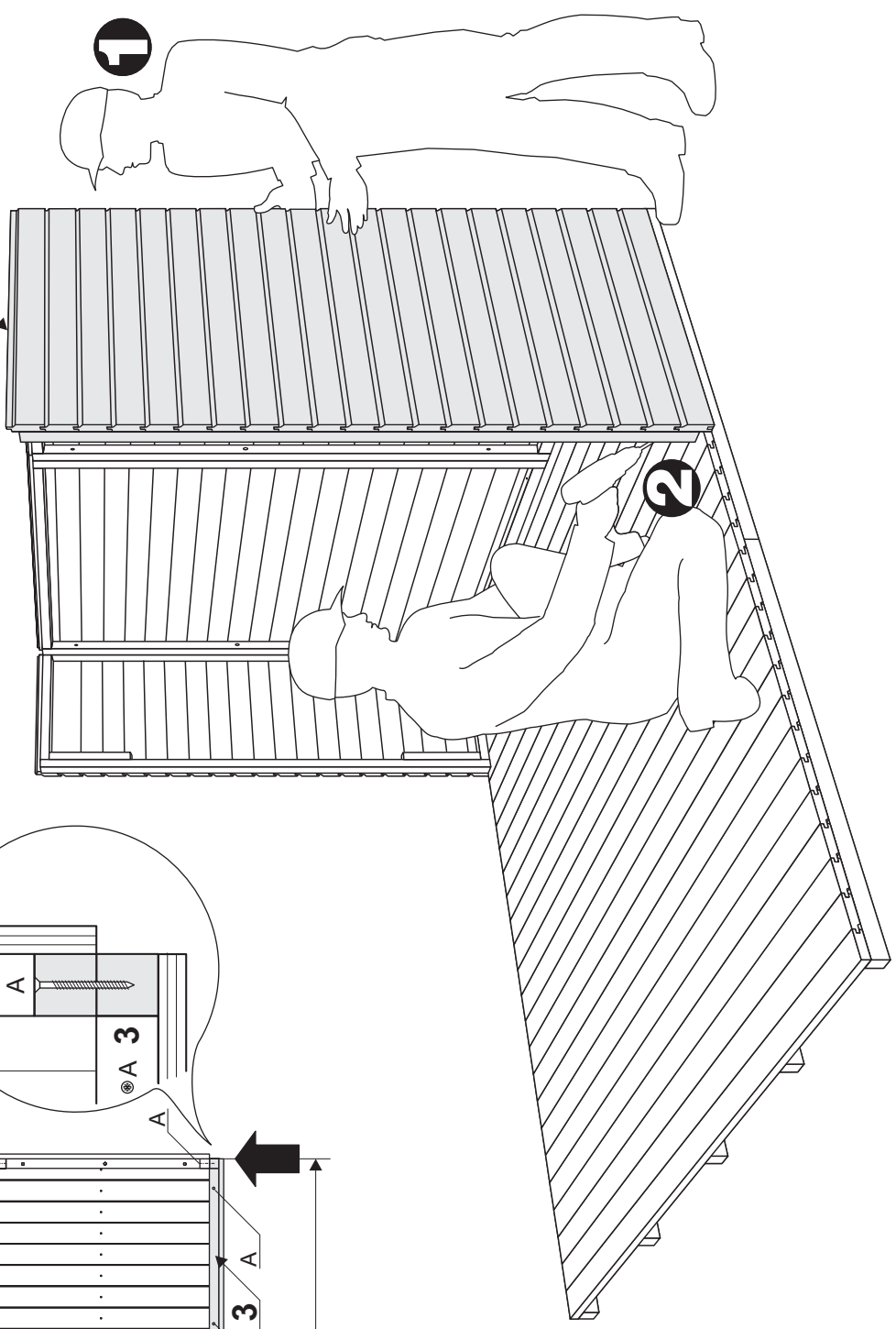
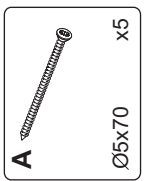
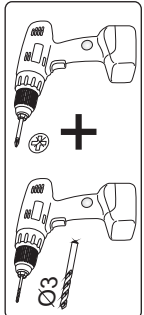
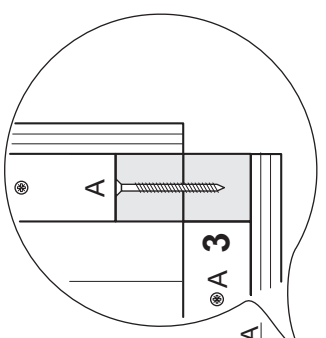
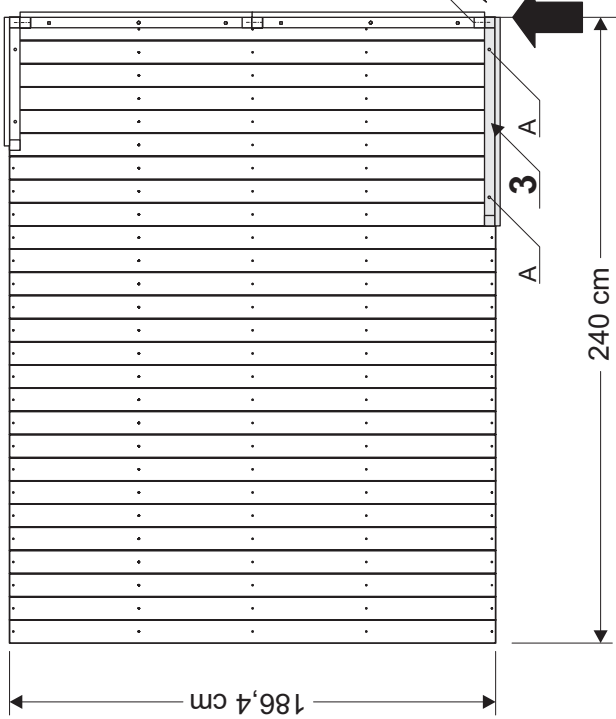

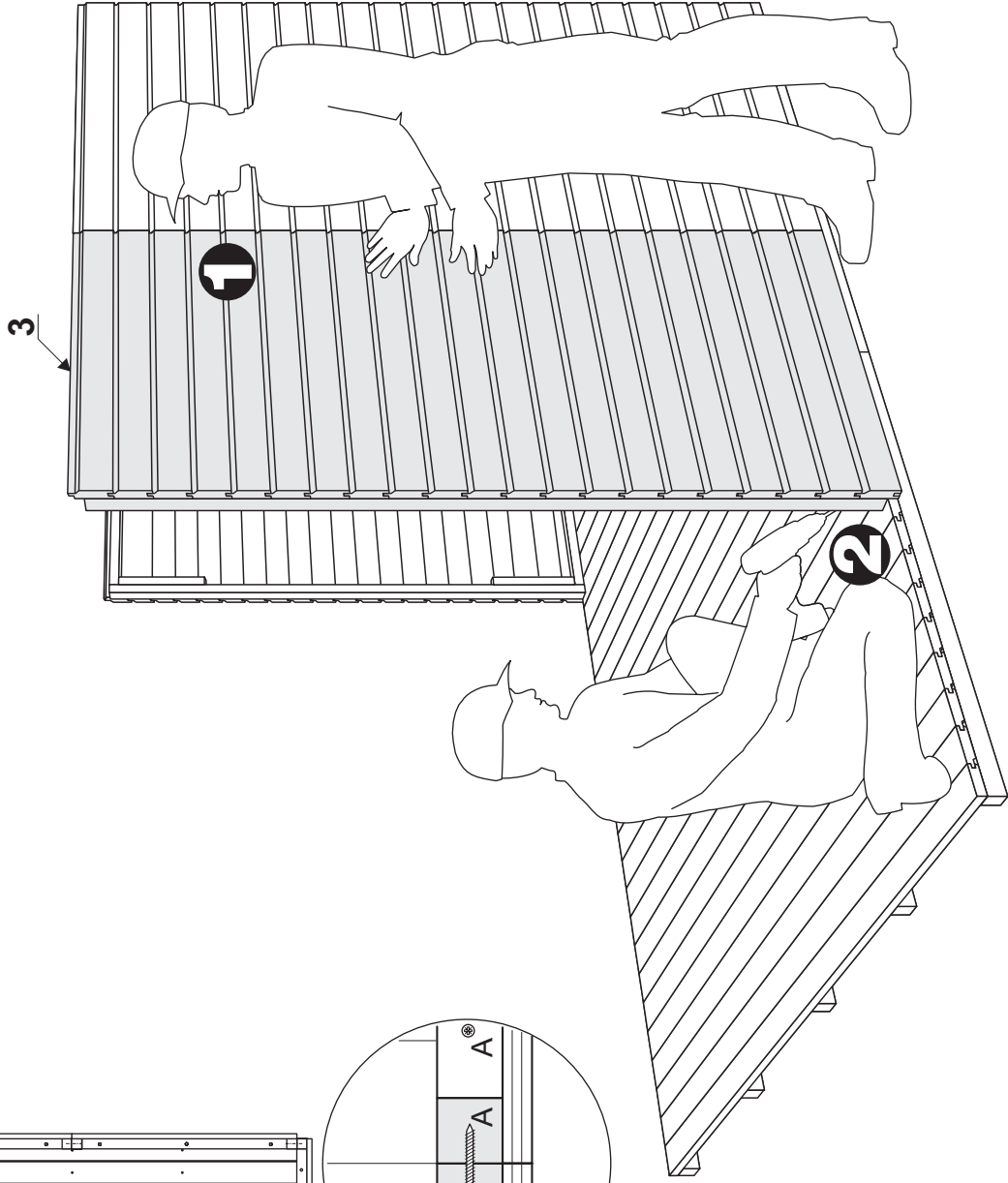
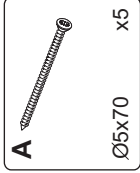
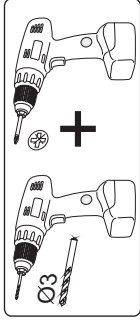
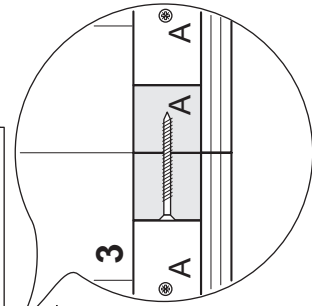
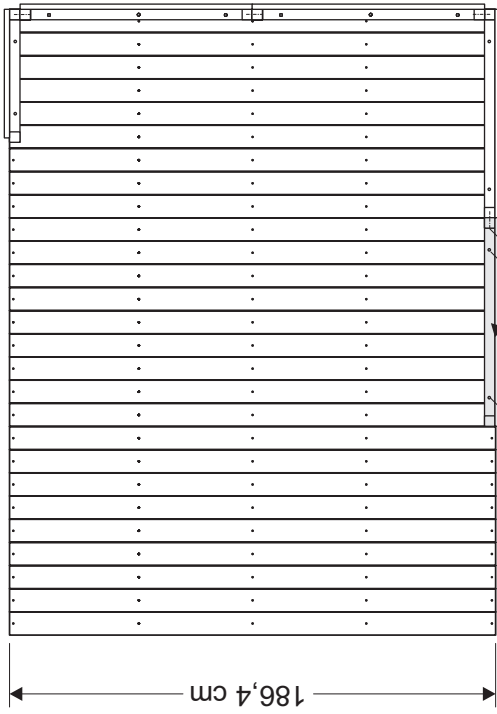

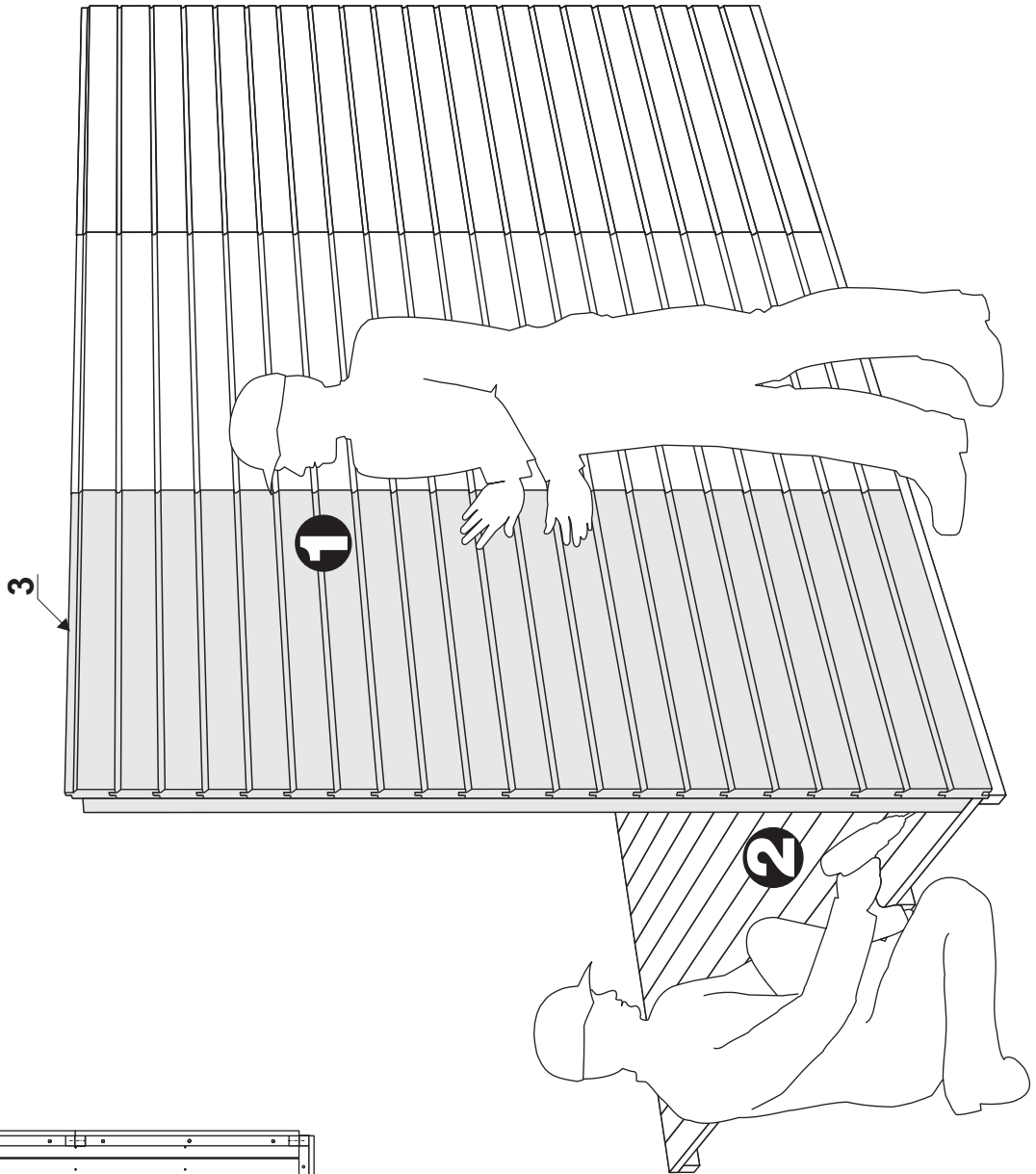
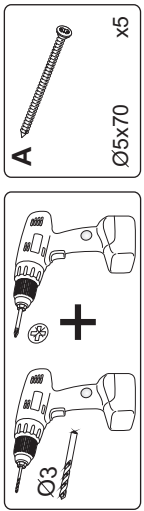
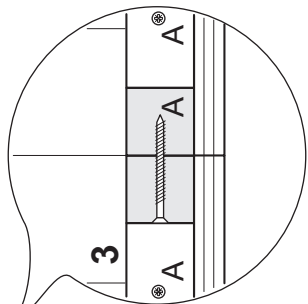
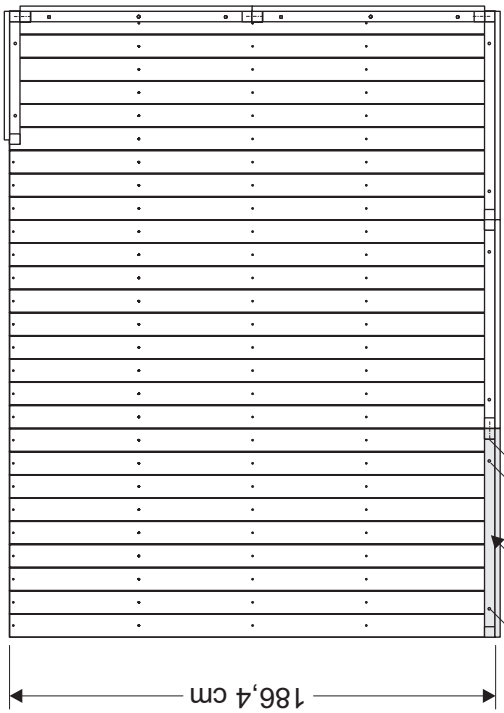

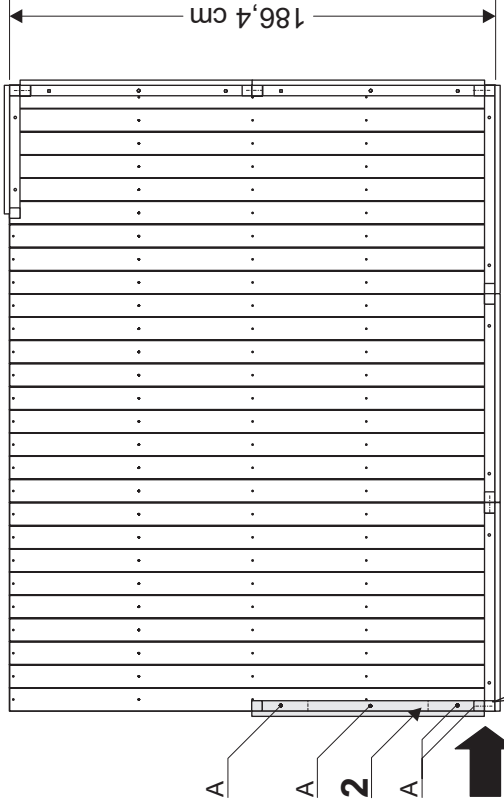

A

Ø5x70

x6

+

Ø3

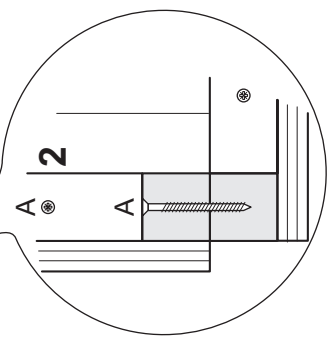
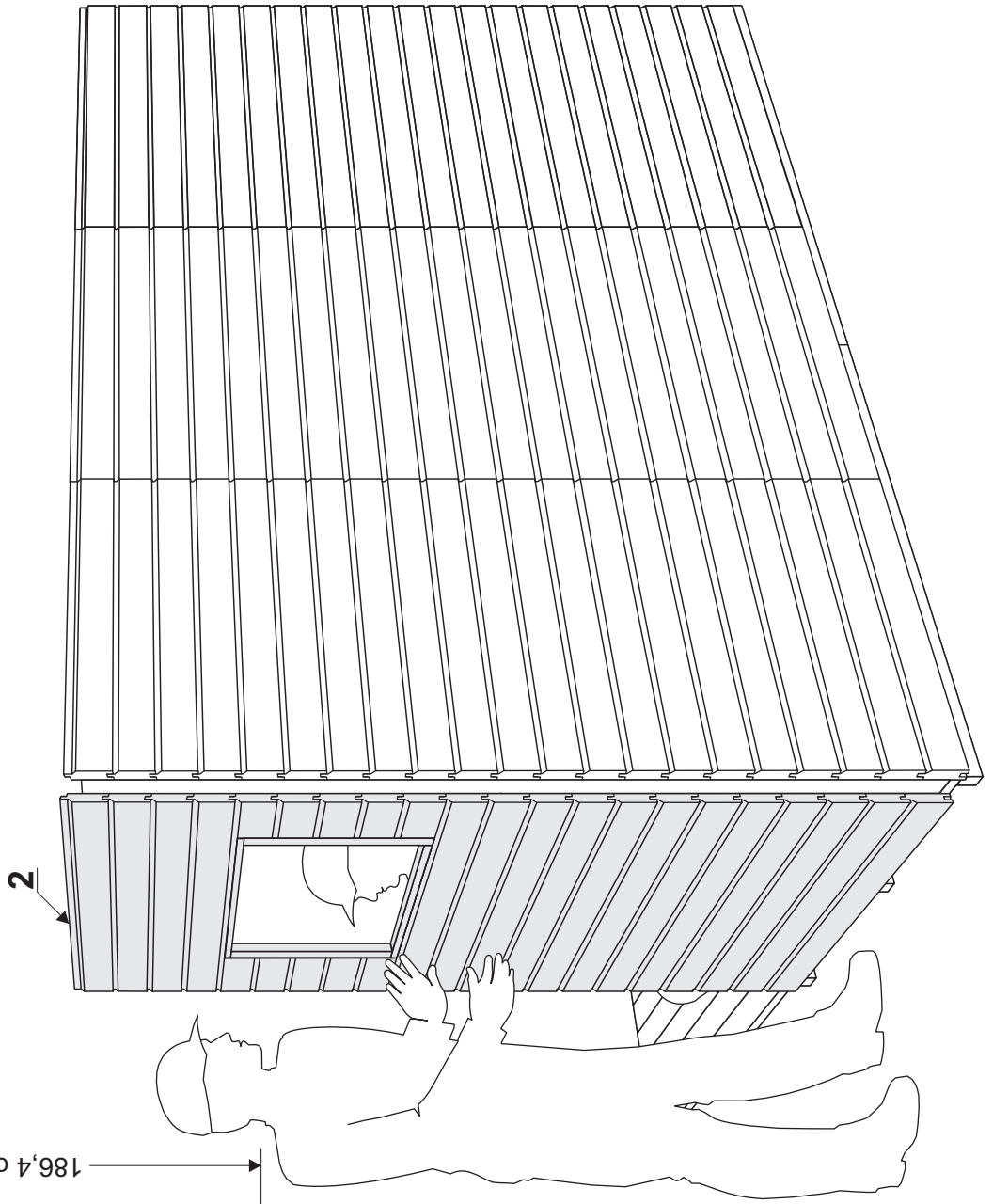

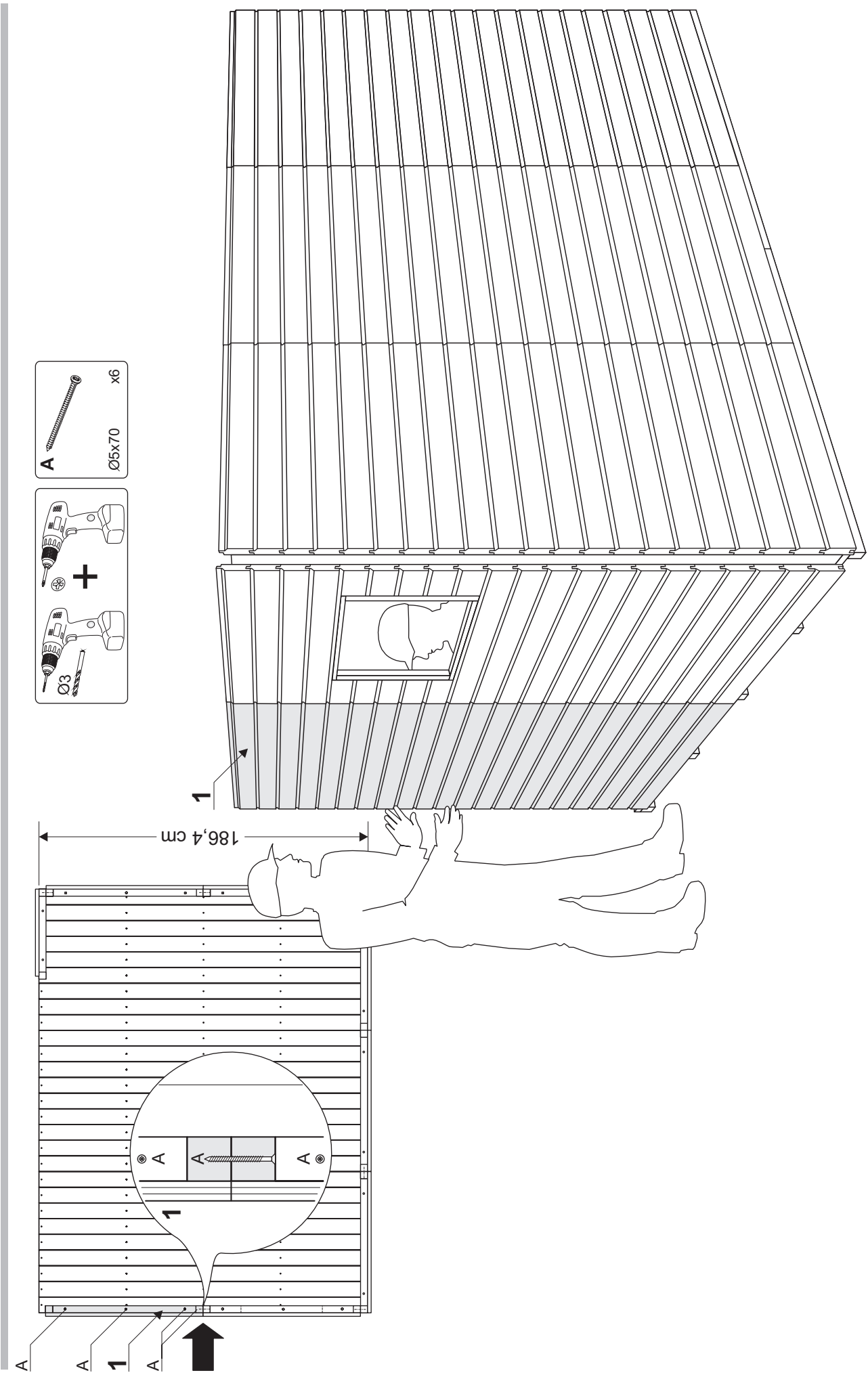

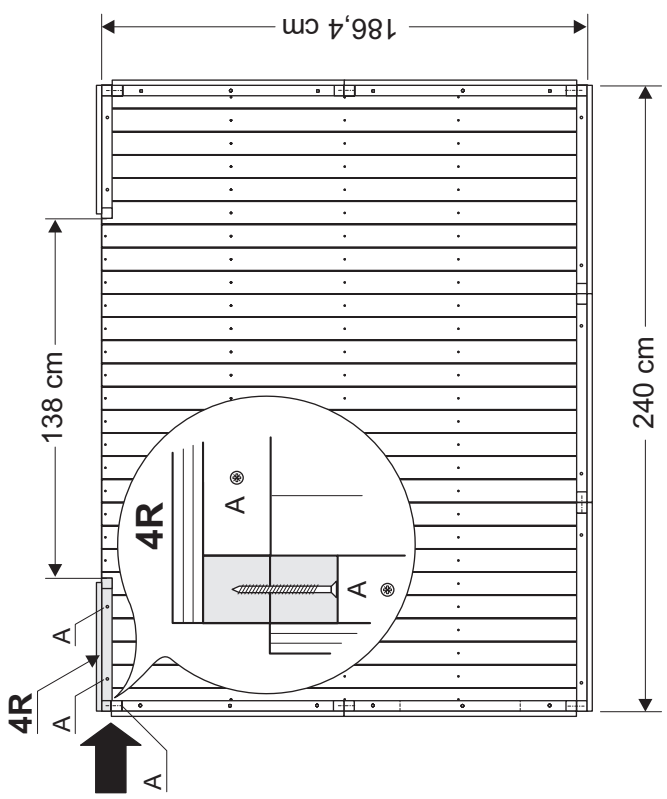
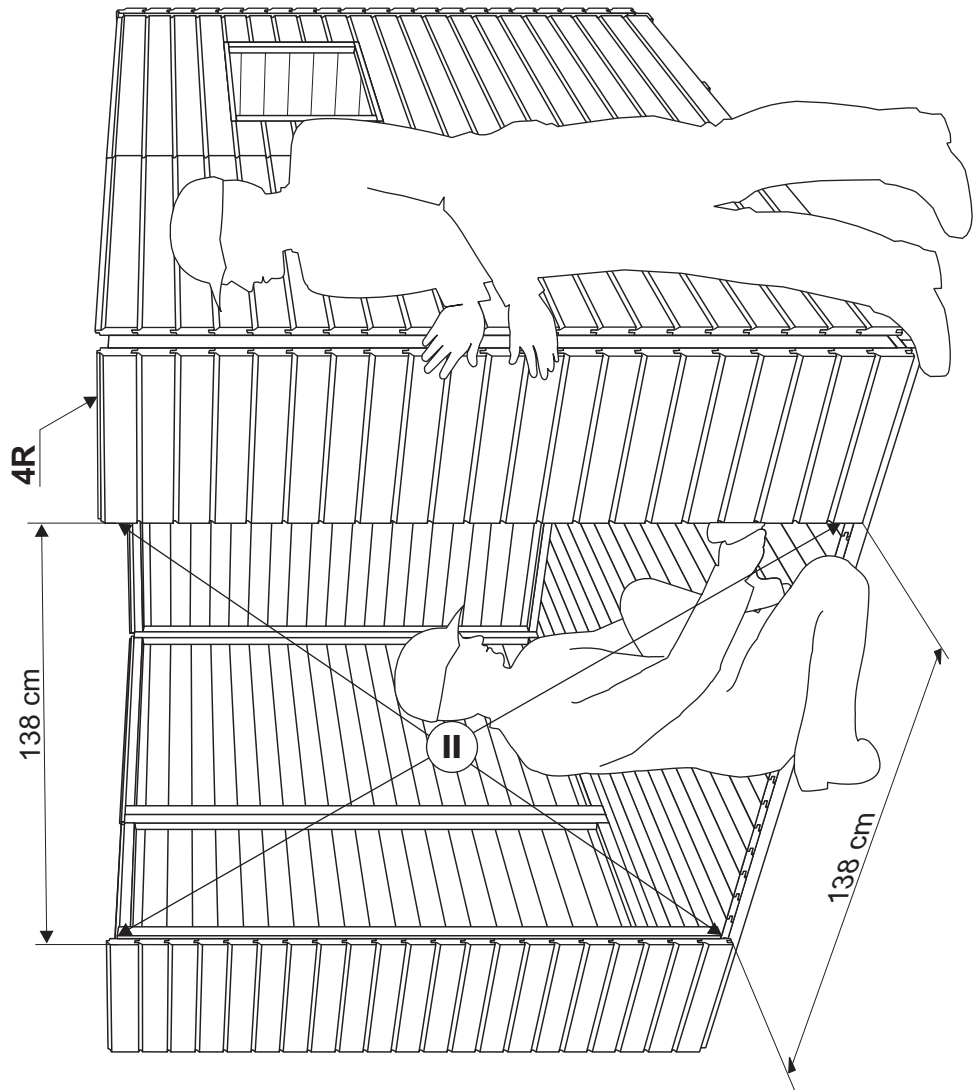
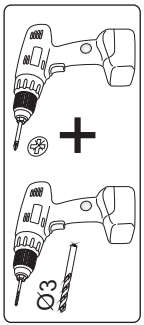
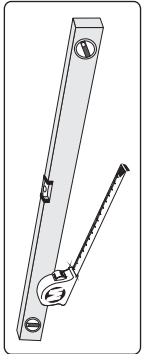
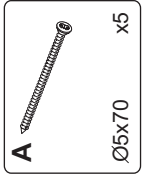

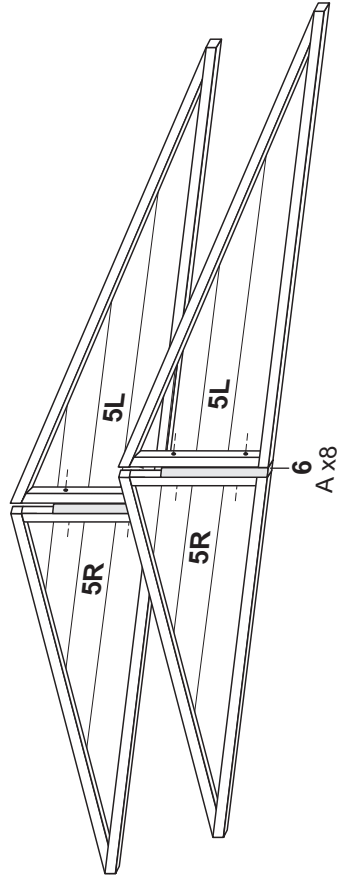
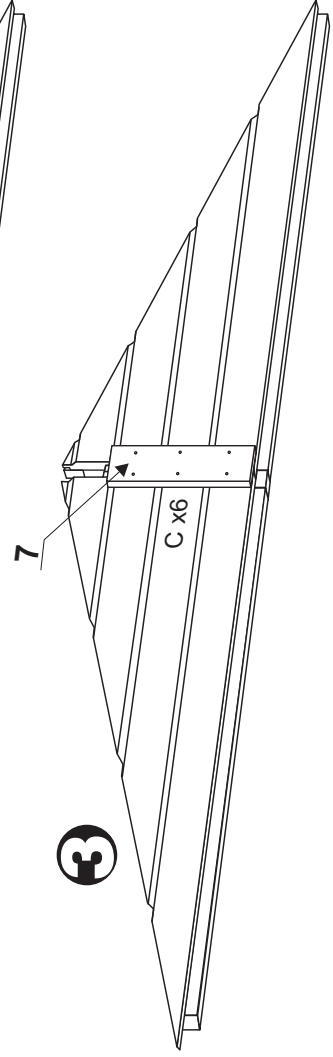
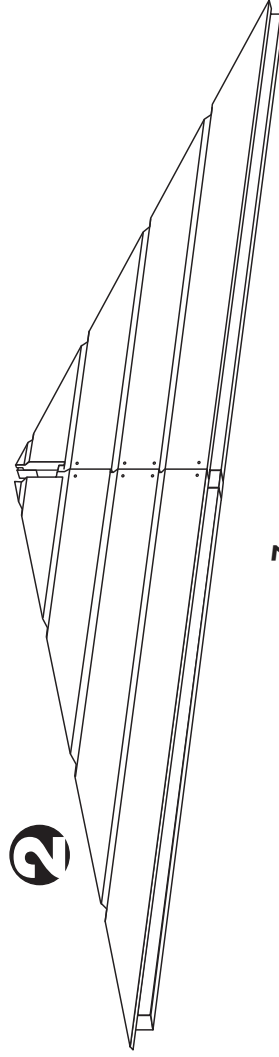
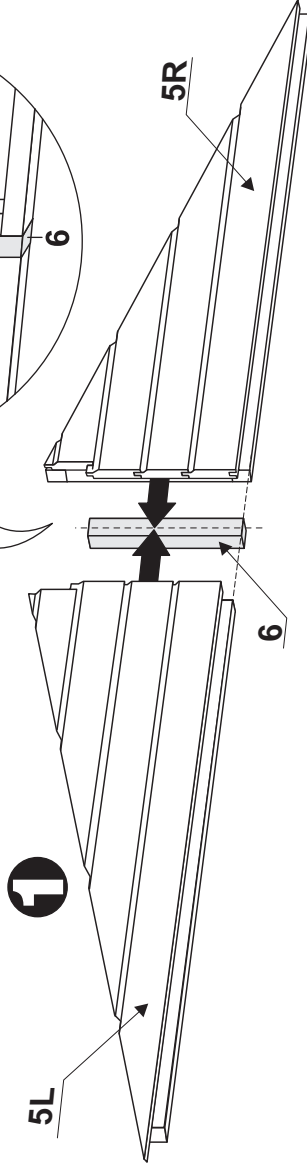
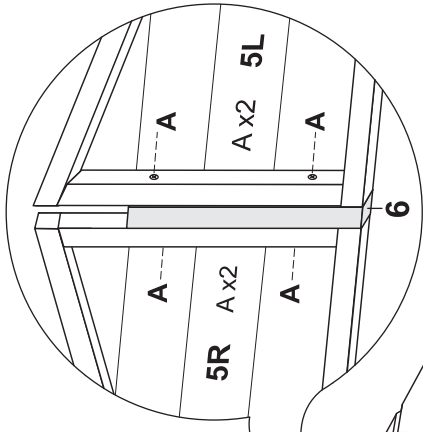
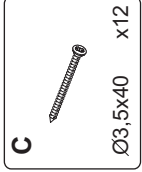
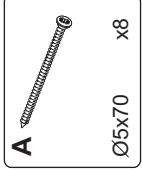
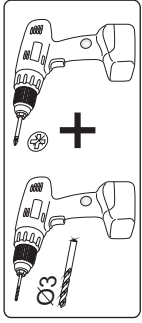
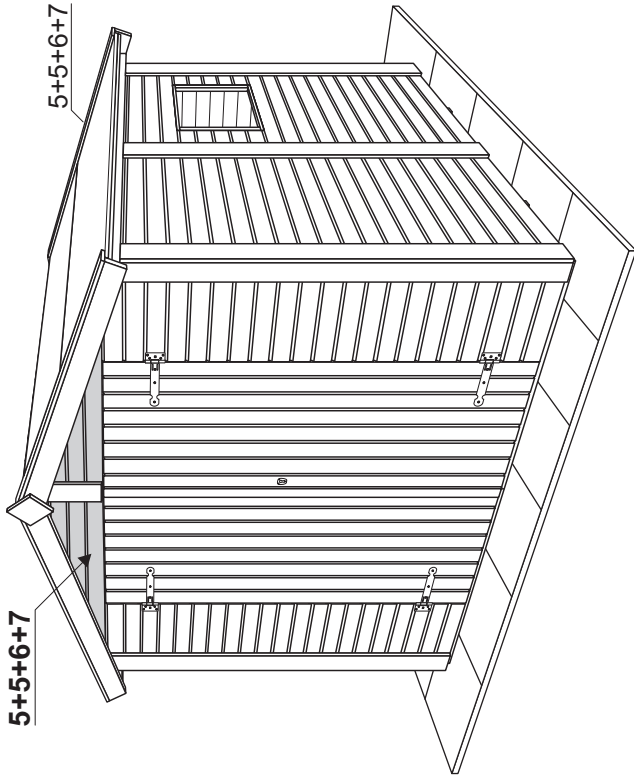

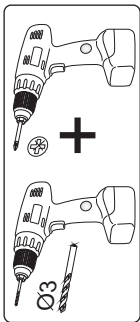

A
Ø5x70 x10

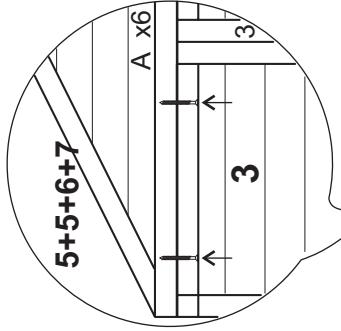
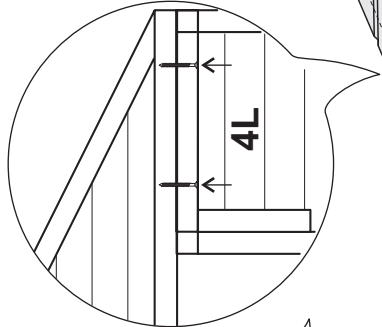
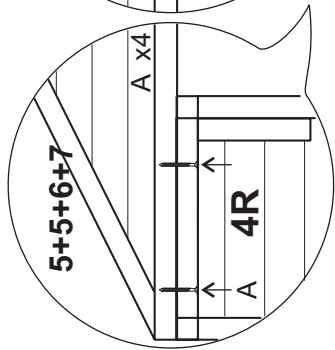

5+5+6+7

5+5+6+7

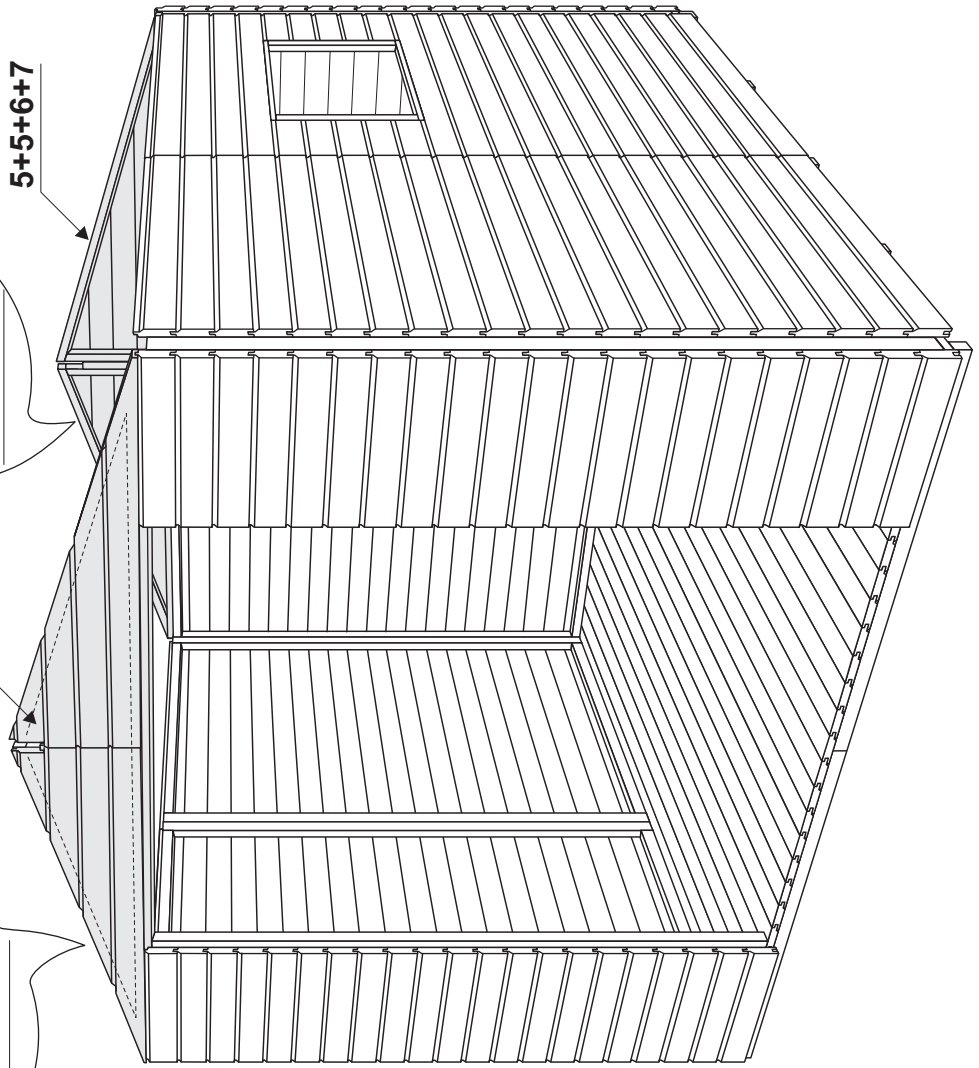

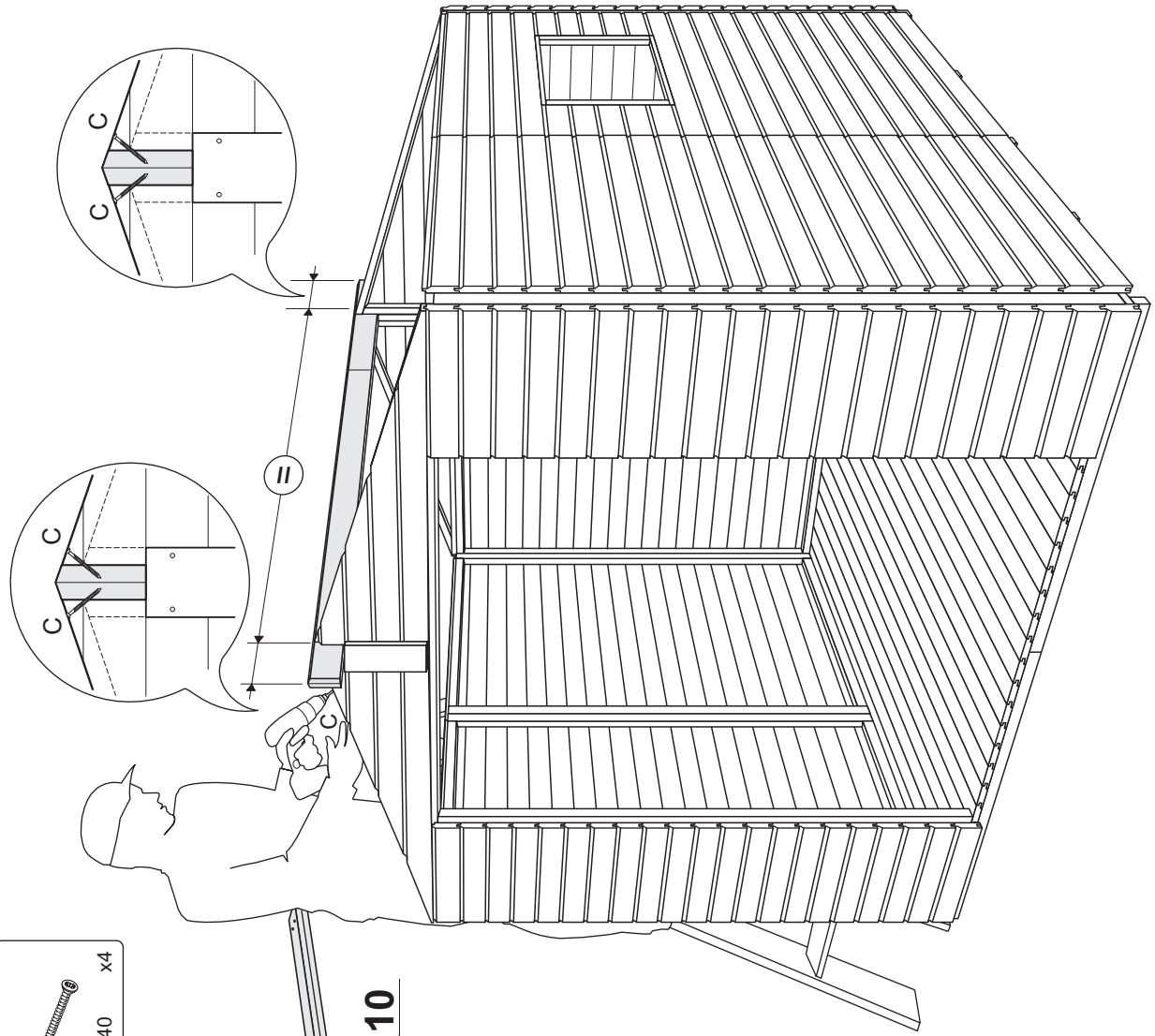
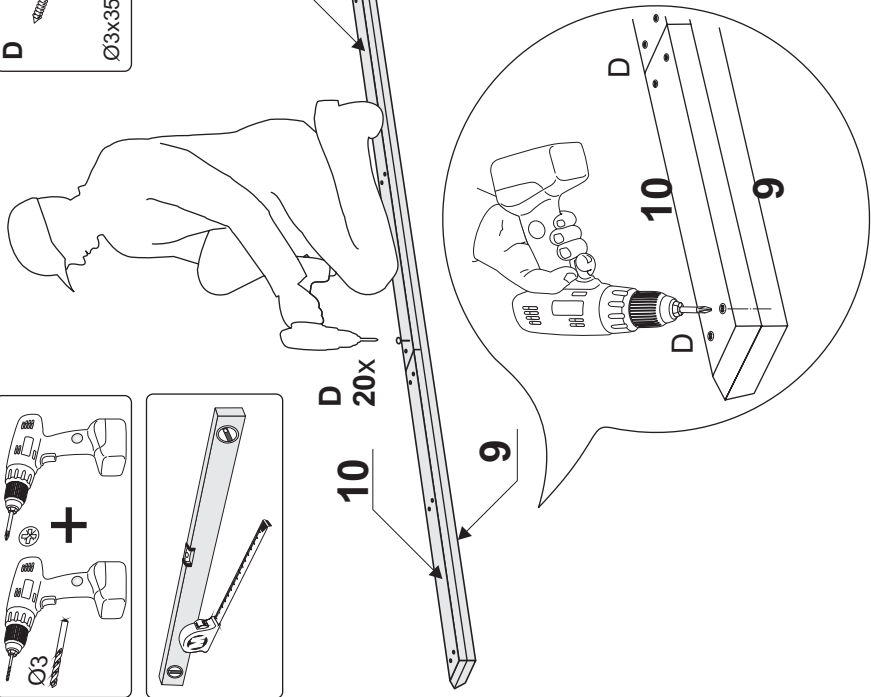
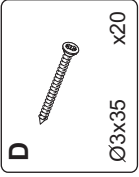
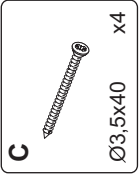
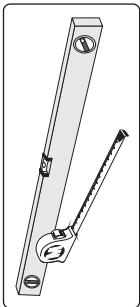
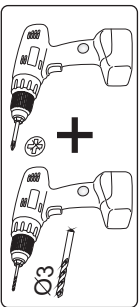

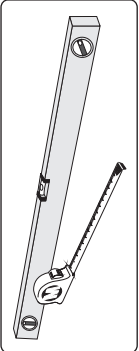

C
Ø3,5x40 x20

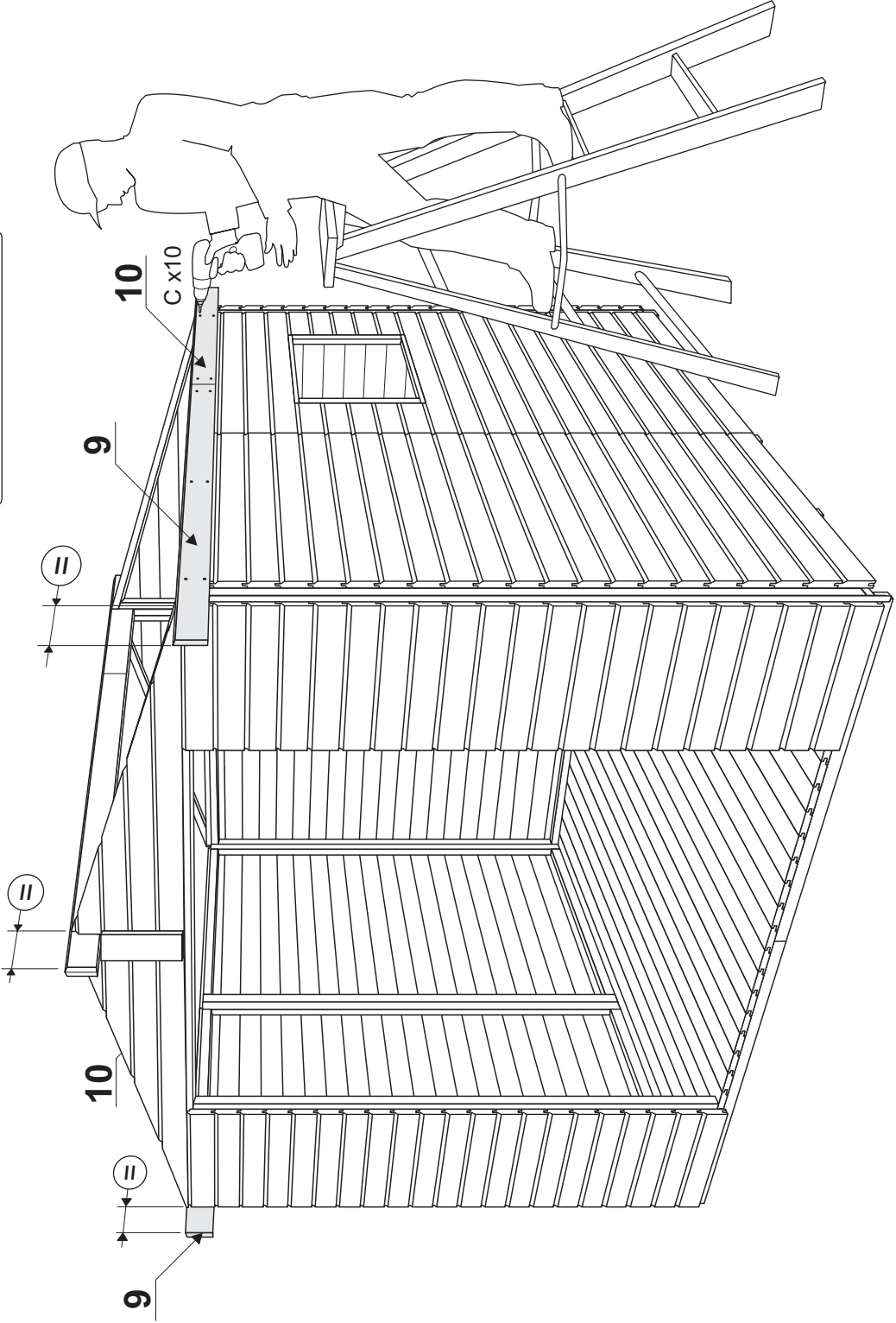
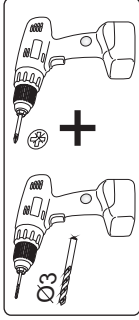

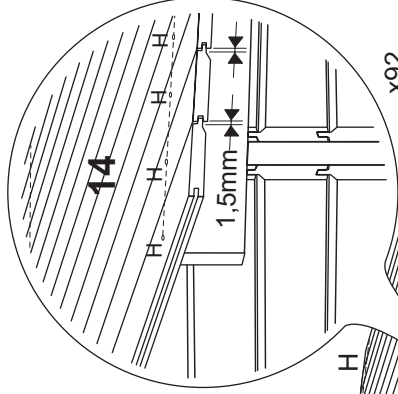
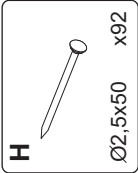
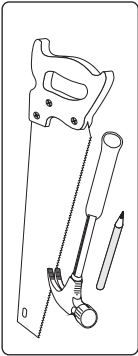

14

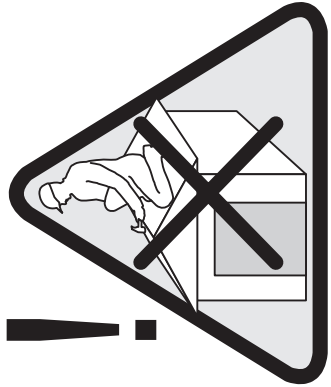
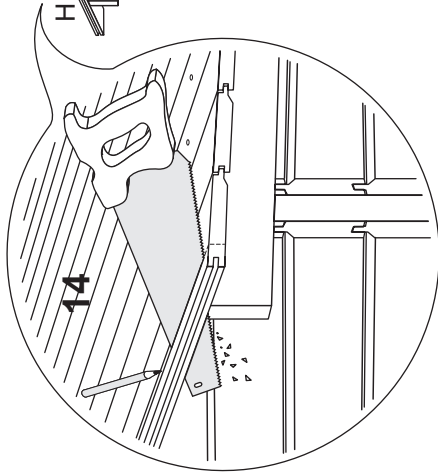
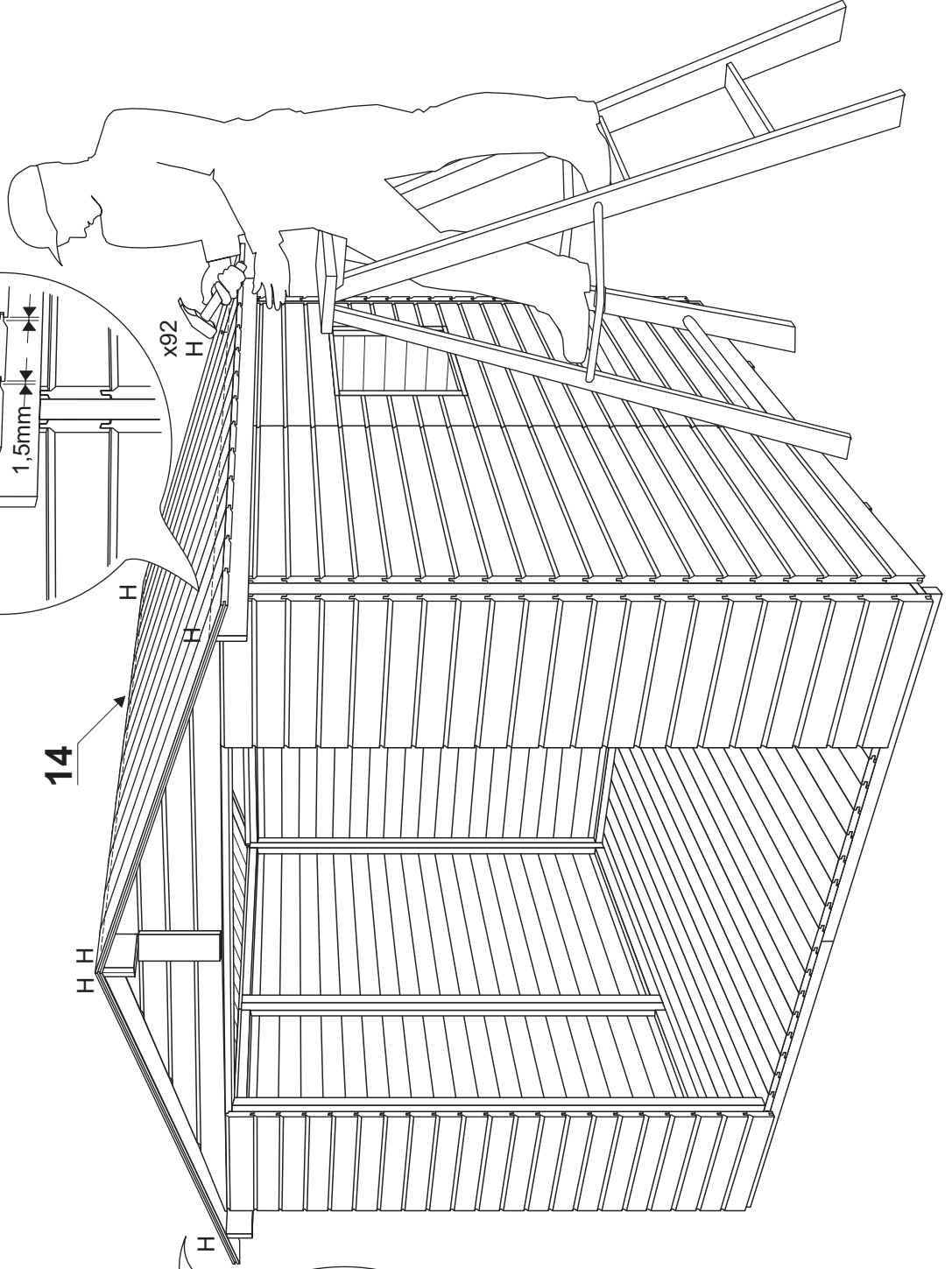

!

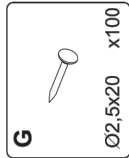

OPTIONAL !!!





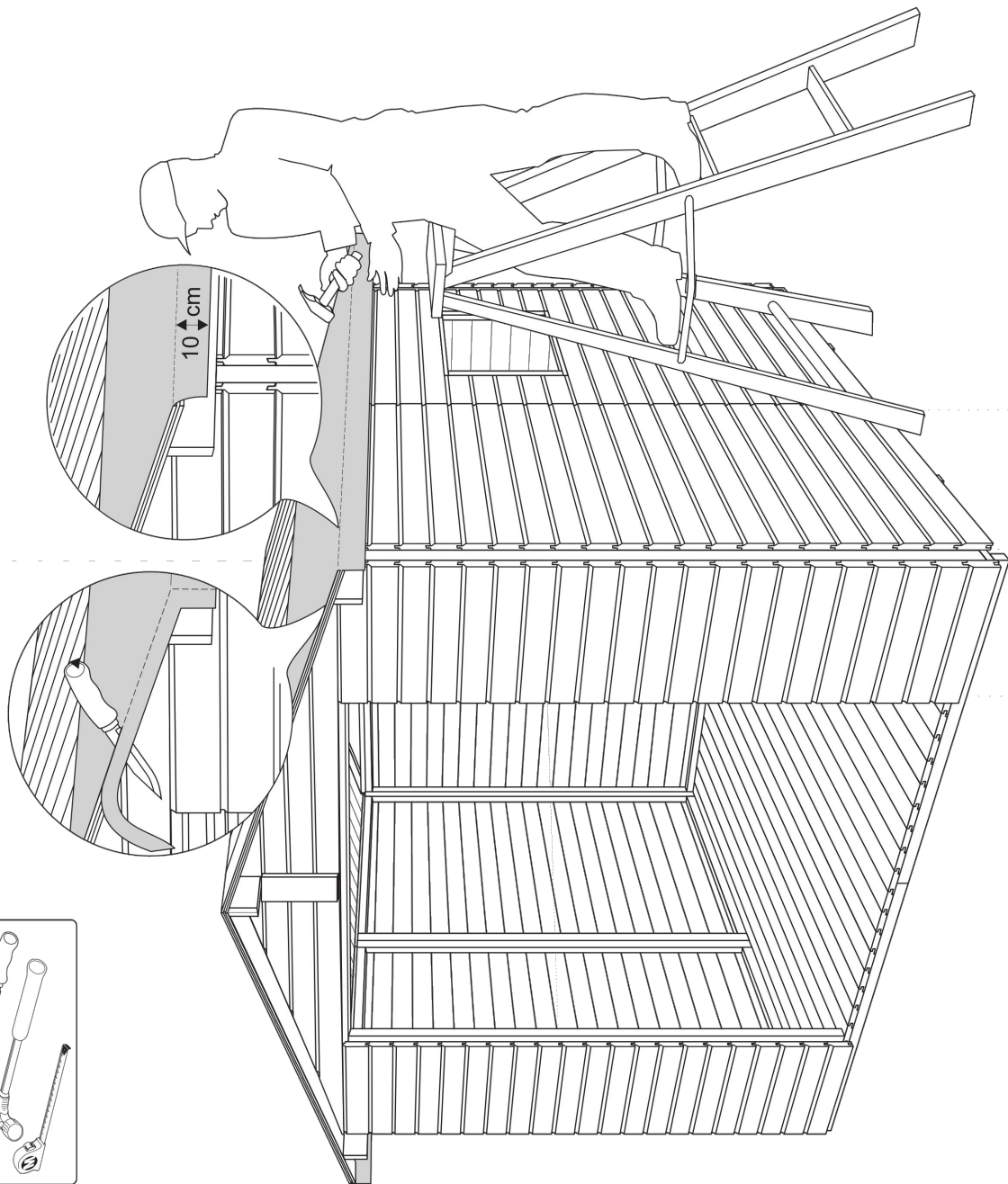
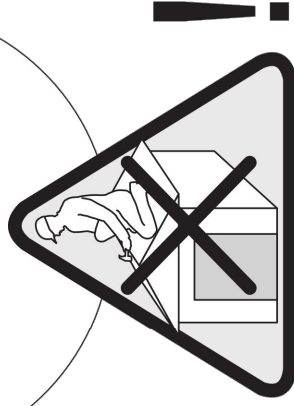
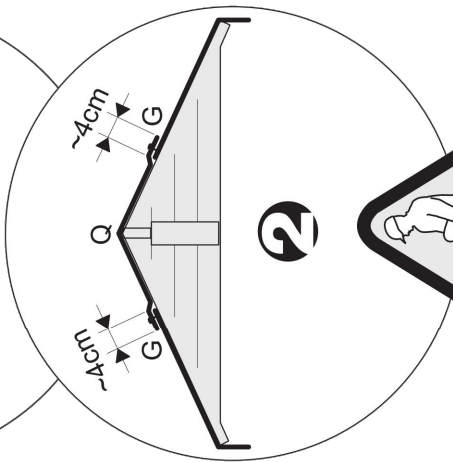
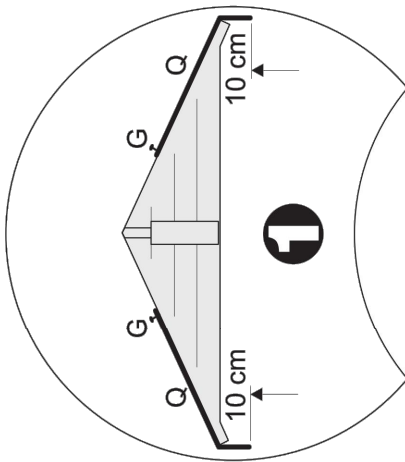
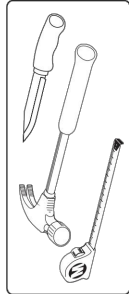

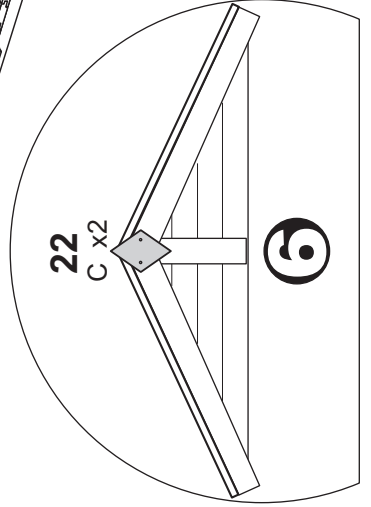
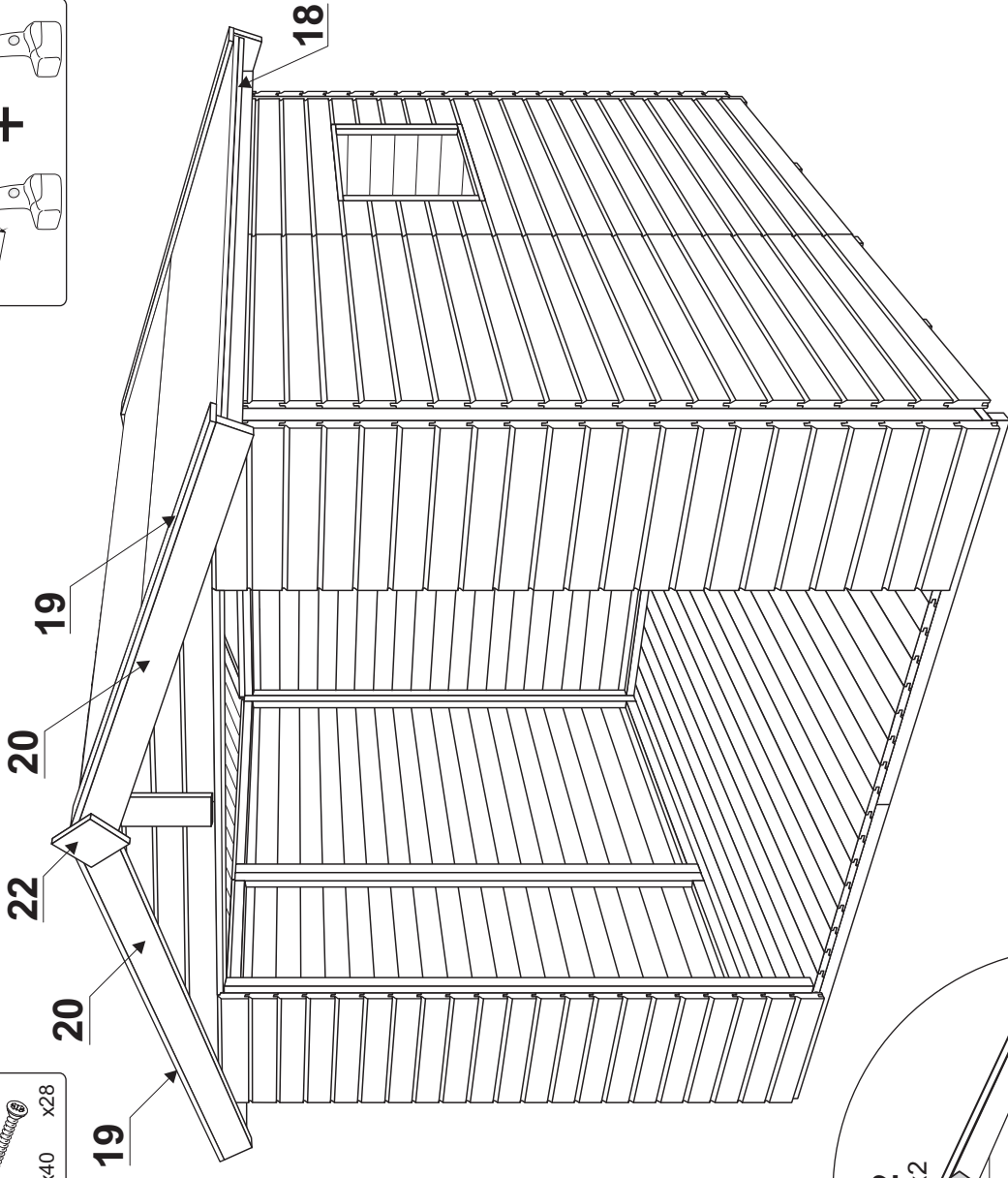
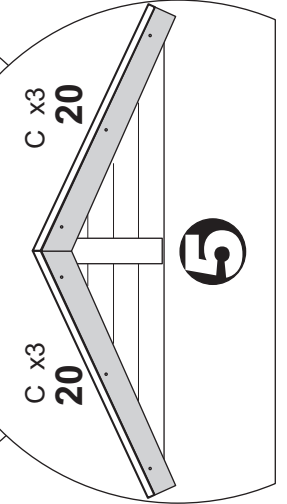
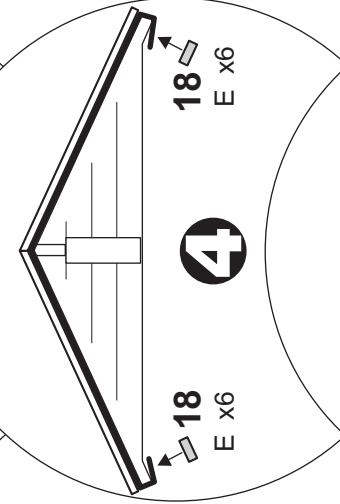
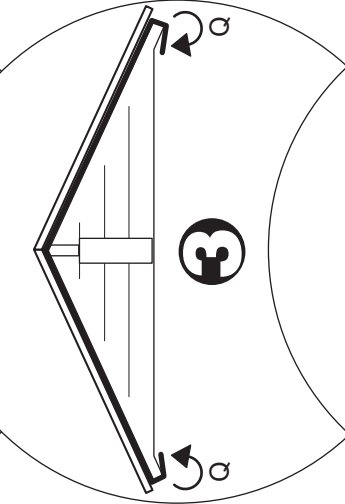
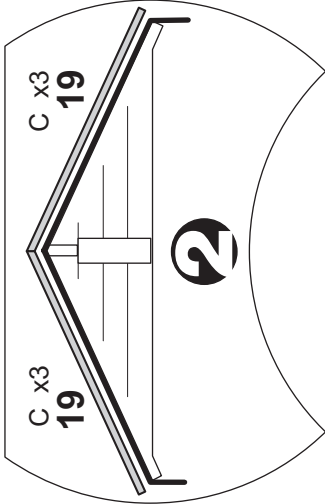
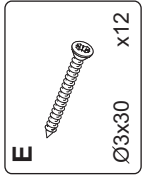
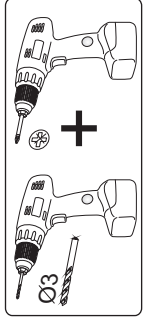
OPTIONAL !!!

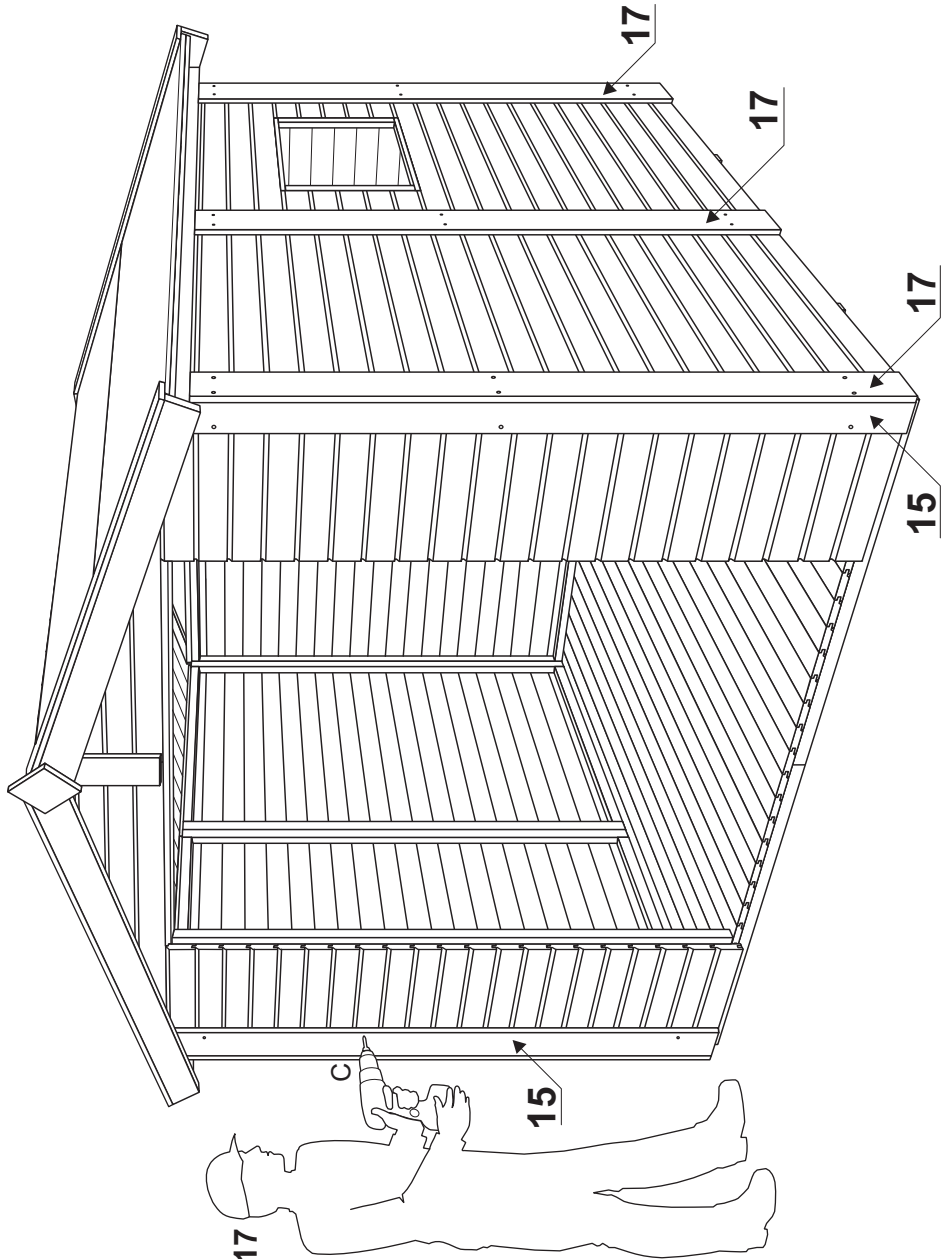
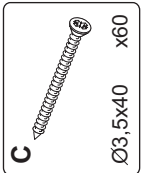
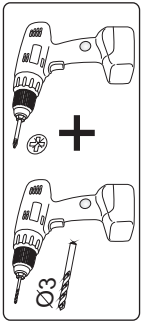
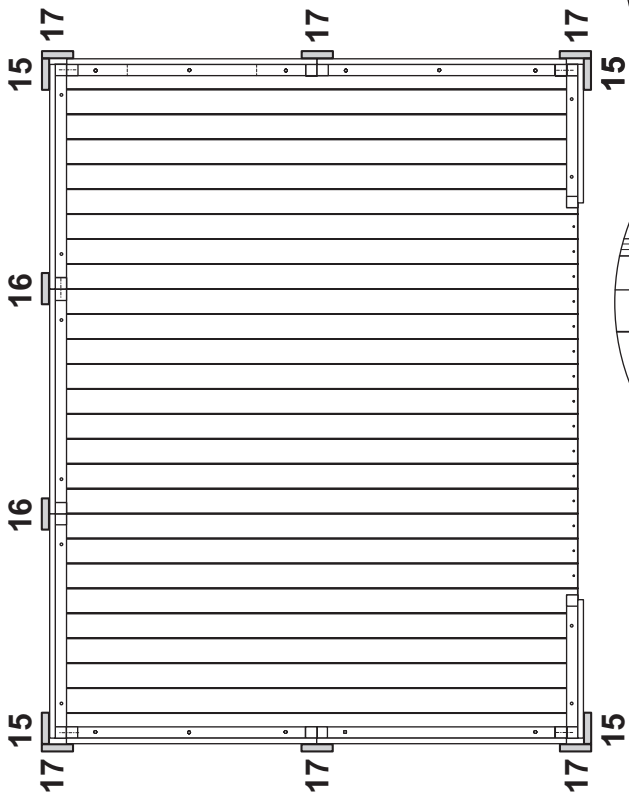

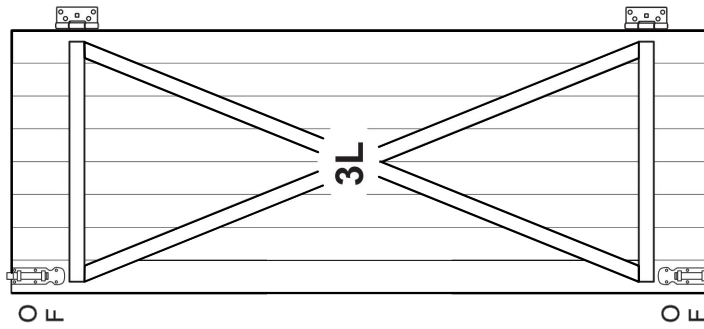
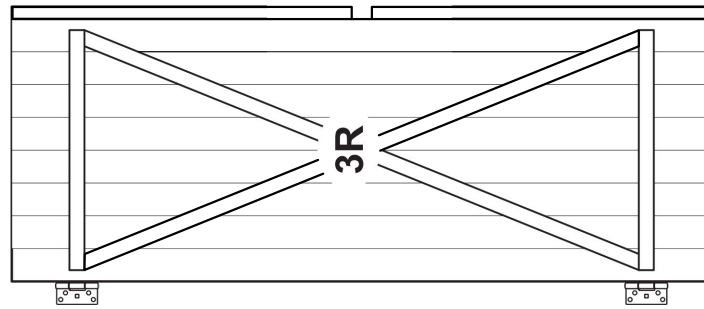
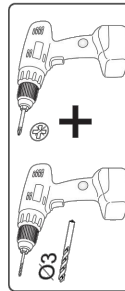
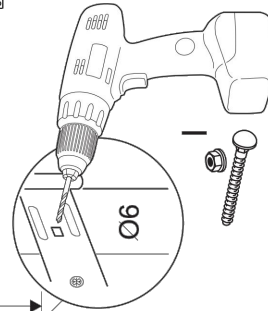
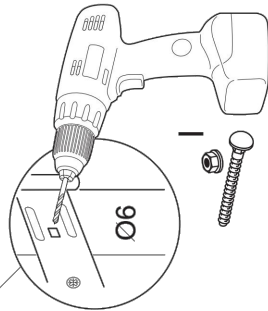
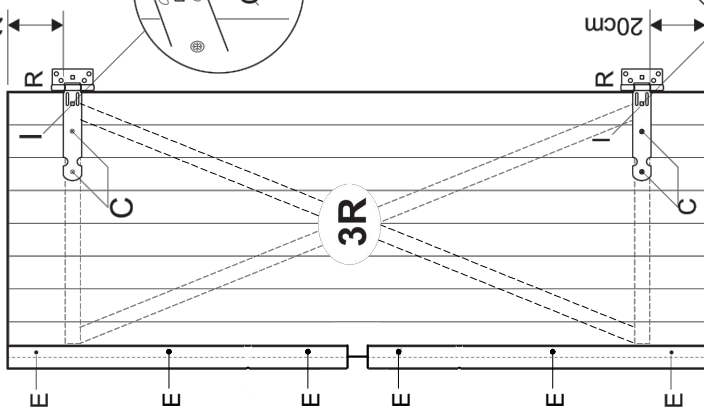
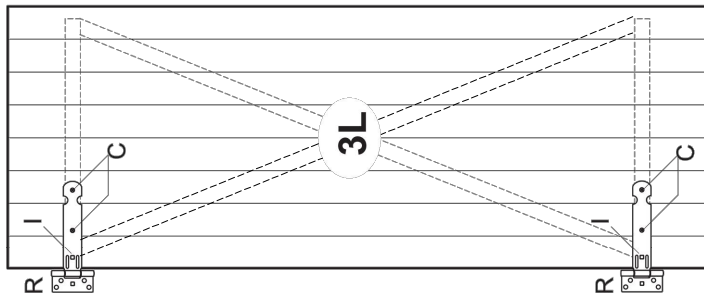
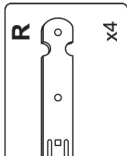
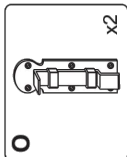
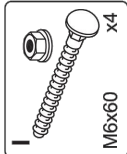
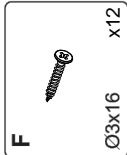
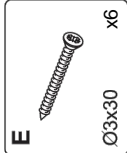



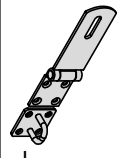

- C**  Ø3,5x40 x16
- I**  M6x60 x4
- F**  Ø3x16 x12
- P**  x2
- L**  x1

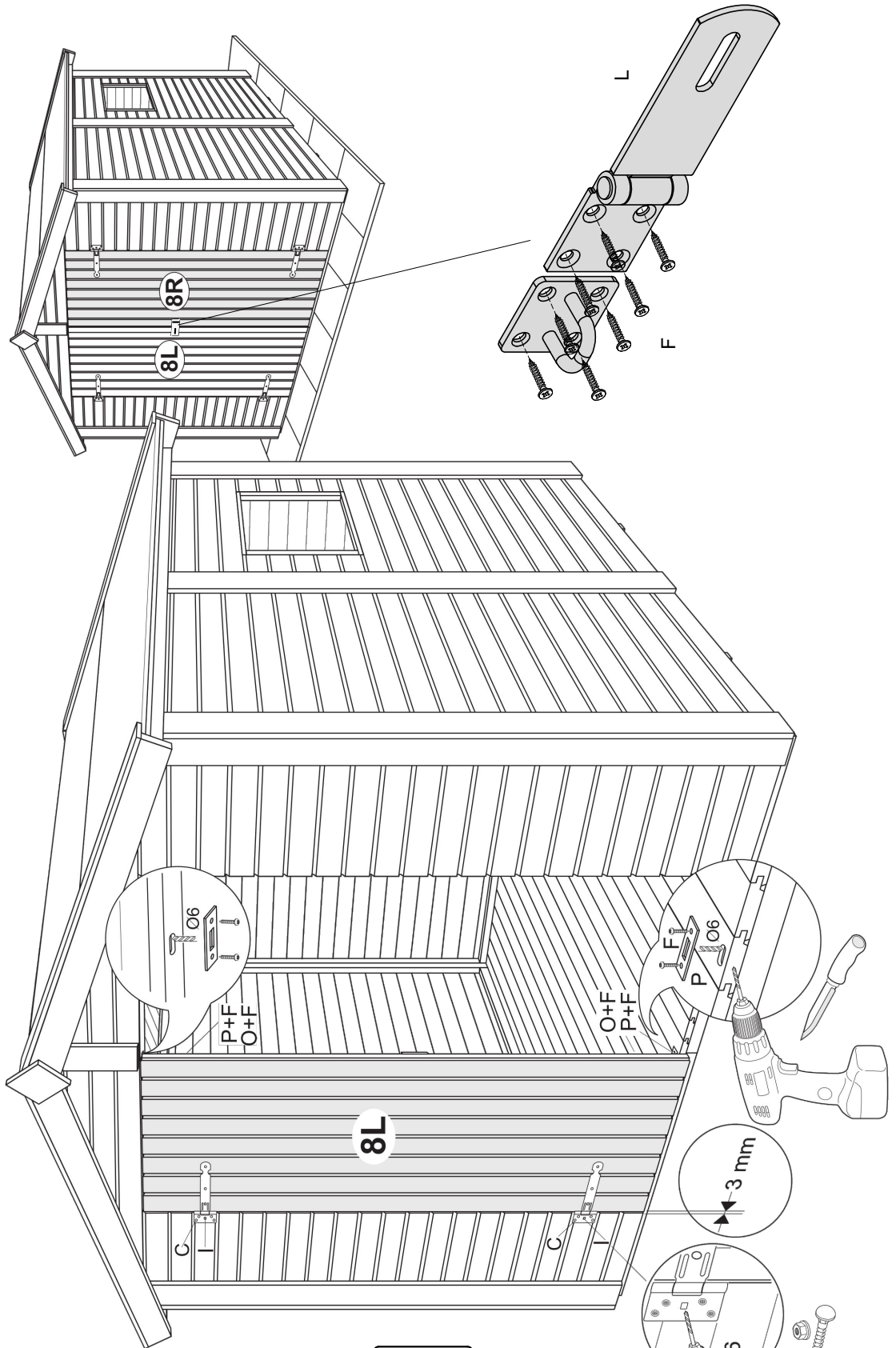

3 mm

